



Color & Comfort



PRODUCT GUIDE

Polyphenylene Sulfide (PPS)

DIC Corporation

DIC.PPS
Polyphenylene Sulfide

BASIC PROPERTIES OF DIC.PPS

Mechanical, Thermal, Electrical, Processing & Other Properties.

Please read before use

Safety Information:

See 'Precaution for molding' in this brochure and Safety Data Sheet for safety precautions during use.

Important Notice to User:

1. The Information contained in this brochure includes general property data of DIC.PPS and serves as a guide for the selection of DIC.PPS grades.
2. The Information is based on tests or researches DIC believes to be reliable. However, no warranty is given by DIC concerning the accuracy or completeness thereof.
3. This Information does not release the user from the obligation to test the Products as to their suitability for the intended applications and processes.
4. DIC assumes no liability for any consequence of the application, processing or use of the Information or the Products.
5. The information concerning the application of the Products is not and should not be construed as a warranty as to non-infringement of intellectual property for a particular application.
6. When exporting DIC.PPS filled and reinforced with specific carbon fibers, represented by the product grade of GZ-1130, GZL-5000, etc., an approval from the Japanese government might be required. It is customer's responsibility to determine the necessity of this licensing procedure and the acquisition.
7. The following standard processing conditions are adopted for preparing test pieces unless mentioned otherwise in this brochure.

Pre drying: 130°C/4hrs.,

Cylinder set temperature: 320 °C,

Injection rate: 1 sec.

Holding pressure: 60 MPa and

Mold set temperature: 150 °C.

CONTENTS

SAFETY INFORMATIONS	P.1	5. OTHER PROPERTIES	P.17
1. GENERAL INFORMATION	P.2	6. MOLDING PROCESS	P.18
2. PROPERTIES OF POLYMER	P.3	7. SECONDARY OPERATION	P.26
3. VARIATIONS OF DIC.PPS	P.4	Precautions for Molding	P.29
4. KEY PROPERTIES OF DIC.PPS	P.5		



1. GENERAL INFORMATION

Polyphenylene sulfide (PPS) is a crystalline heat-resistant polymer with the chemical structure as shown in Figure 1.1. PPS has a high melting point of about 280 °C, excellent chemical resistance and non-flammable properties that exhibit self-extinguishing properties without the addition of flame retardants.

DIC.PPS is an engineering thermoplastic which PPS is reinforced and/or filled with reinforcing materials such as glass fibers and inorganic fillers. DIC.PPS exhibits excellent mechanical stability, heat resistance and dimensional stability.

There are two types of DIC.PPS: branched and linear. The branched polymer which maintains high rigidity at high temperatures, has good creep deformation resistance. The linear polymer has better strain (elongation) and toughness. In addition, the linear polymer is of higher purity, and therefore has less moisture absorption at high temperature and high humidity than the branched polymer.

The exceptional characteristics of DIC.PPS allow the molding of parts that can meet the high performance demand in various areas such as the automotive, electrical and electronic industries. For instance, DIC.PPS can meet the following demands:

- Heat resistance that requires continuous use at temperature higher than 200°C
- High rigidity and strength retention over a wide temperature range
- Resin-specific flame retardancy of UL V-0 rank
- Excellent dimensional stability over a wide range of environmental conditions
- Chemical resistance second to fluoro resin
- Good electrical properties under high temperature, humidity and frequency
- Complex high-precision molding is possible

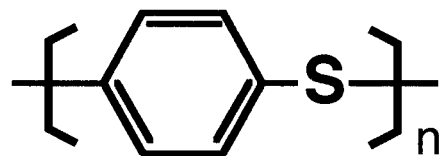

Fig.1.1 PPS is a simple chemical construction consisting of benzene ring and sulfur atom

DIC.PPS

2. PROPERTIES OF POLYMER

2.1. General Properties

PPS polymer exhibits exceptional resistance to thermal oxidative degradation. The decomposition temperature, as determined by thermo-gravimetric analysis (TGA), is over 500°C in air as well as in nitrogen atmosphere (Figure 2.1). The high decomposition temperature in air is indicative of PPS's outstanding heat resistant stability under oxidative conditions.

PPS polymer is a semi-crystalline polymer as shown in Figure 2.2 with a glass transition temperature (T_g) of approximately 90°C, and with a melting point (m.p.) of about 280°C and with a recrystallization temperature,

(T_{c1}) of about 125°C. These temperatures have important implications for various properties, including the mechanical properties of molded products.

At temperatures above the glass transition temperature, mechanical properties (4.1 mechanical properties) and dimensions (4.4.1 linear expansion coefficient) of PPS change rapidly. Additionally, if parts are molded at low temperatures, crystallization of the amorphous phase progresses when heated above T_{c1} resulting in the change of dimension.

Figure 2.3 shows the viscoelastic behavior of PPS polymer (according to ASTM D-5418, frequency 0.1Hz,

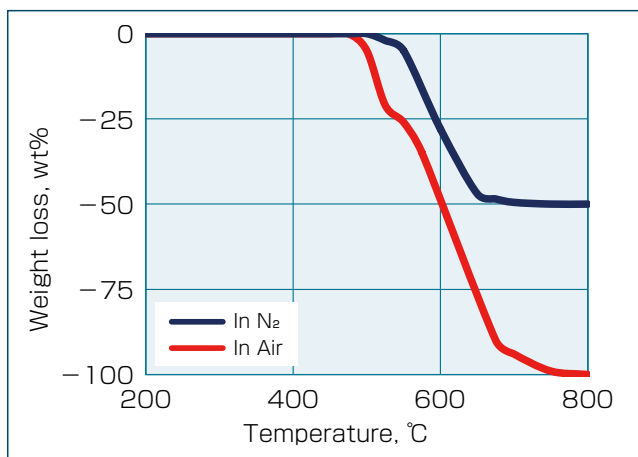

Fig.2.1 Thermal oxidative stability of PPS

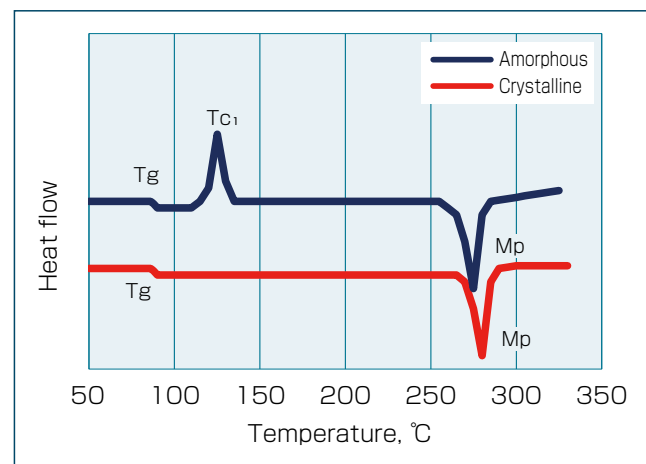

Fig.2.2 DSC chart of PPS polymer

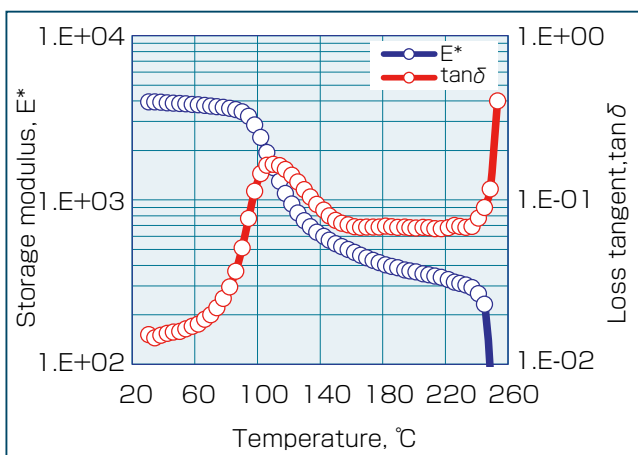

Fig.2.3 Mechanical dumping behavior of PPS

double cantilever bending method). The storage elastic modulus and loss tangent changed abruptly at the glass transition temperature.

2.2. Branched Polymers and Linear Polymers

There are two types of PPS polymers: branched and linear. The branched polymer is heat-treated during the production processes in the presence of oxygen to increase its molecular weight up to the required level.

This branched polymer forms a two-dimensional or three-dimensional branching structure via oxygen. Therefore, the branched polymer shows high rigidity and small creep deformation or relaxation at elevated temperatures when compared to the linear polymer.

On the other hand, the linear polymer shows low modu-

lus and ductility. Besides, this high purity polymer has excellent dimensional stability under hot and wet conditions because of its lower water absorption than that of the branched polymer. Such properties are exemplified in Table 2.1 where the branched polymer shows higher rigidity than that of the linear polymer under a broad range of temperatures.

The comparisons of properties between these two types of PPS based compounds are shown in Figure 2.4.

Table 2.1 Comparisons of storage modulus; E' between branched and linear PPS polymers

Temperature	Branched	Linear
23°C	4,000 MPa	3,700 MPa
80°C	3,700 MPa	3,500 MPa
100°C	2,500 MPa	2,100 MPa
120°C	1,000 MPa	800 MPa
140°C	600 MPa	500 MPa

3. VARIATIONS OF DIC.PPS

DIC.PPS has a wide range of products that can be adapted to various applications and requirements.

- Glass fiber (GF) reinforced heat resistance branched PPS series
- GF & mineral filled heat resistance branched PPS series
- GF reinforced & unreinforced toughness linear PPS series
- GF & mineral filled toughness linear PPS series
- Super tough PPS series
- Self-lubricant, electric conductive series
- Alloy and modified PPS series
- Electrical/electronic encapsulation series

In this brochure, the properties of six representative grades described below are discussed. The other grades are shown in another brochure titled "DIC.PPS Guide Data".

- FZ-1140:GF40% reinforced branched PPS,
- FZ-2140:GF40% reinforced linear PPS,
- FZ-3600: GF and mineral filled branched PPS,
- FZ-6600: GF and mineral filled linear PPS,
- Z-230: GF30% reinforced super tough PPS
- Z-650: GF and mineral filled super tough PPS.

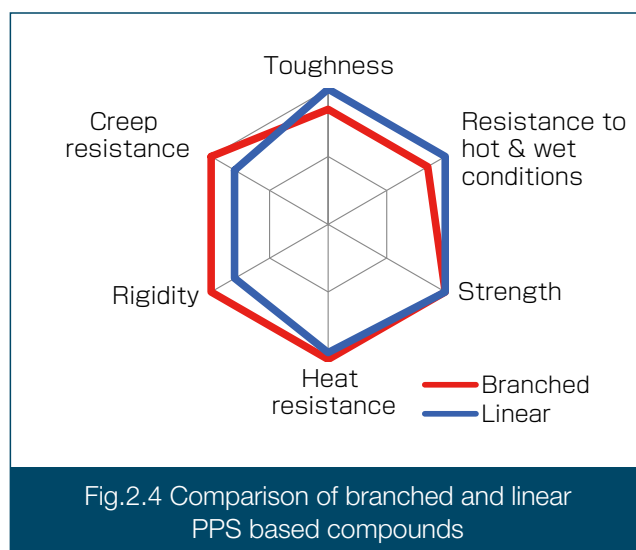

Fig.2.4 Comparison of branched and linear PPS based compounds

4. KEY PROPERTIES OF DIC.PPS

4.1. Short-Term Mechanical Properties

DIC.PPS shows excellent mechanical properties over a wide temperature range. Figure 4.1 shows the tensile stress-strain curves at room temperature for the six representative grades. Figure 4.2 illustrates the relationship between tensile strength

and temperature. Figure 4.3 and Figure 4.4 show the relationship between flexural strength and temperature, flexural modulus and temperature, respectively. In these figures, at temperatures above 90°C, which is the T_g of PPS, strength and rigidity fall gradually. However, under the high temperature of 200°C, DIC.PPS retains about 30% of its

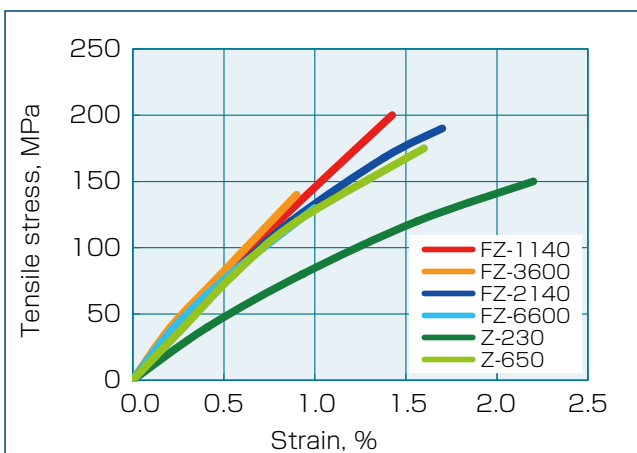

Fig.4.1 Tensile stress-strain curves.

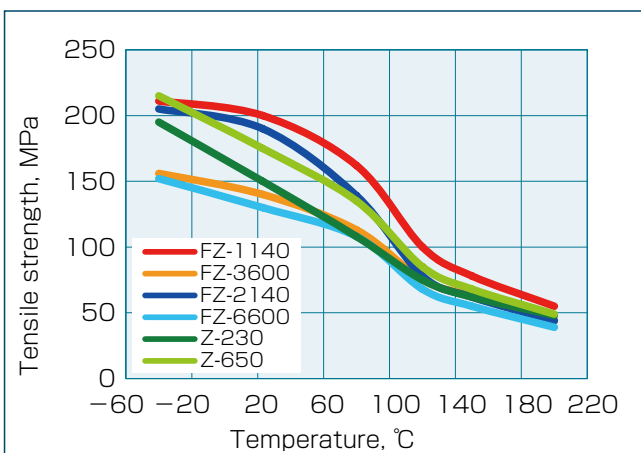

Fig.4.2 Effect of temperature on tensile strength

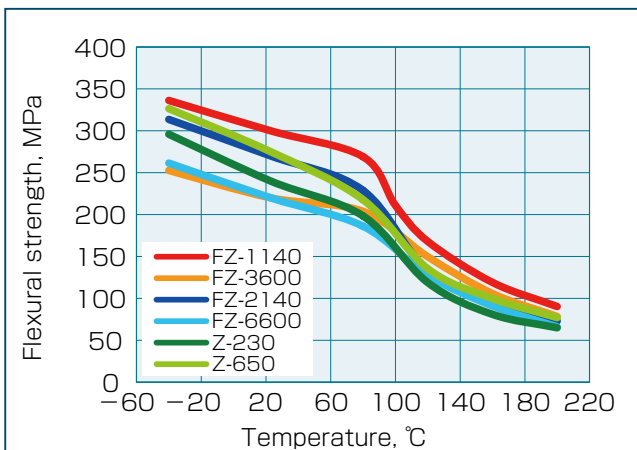

Fig.4.3 Effect of temperature on flexural strength

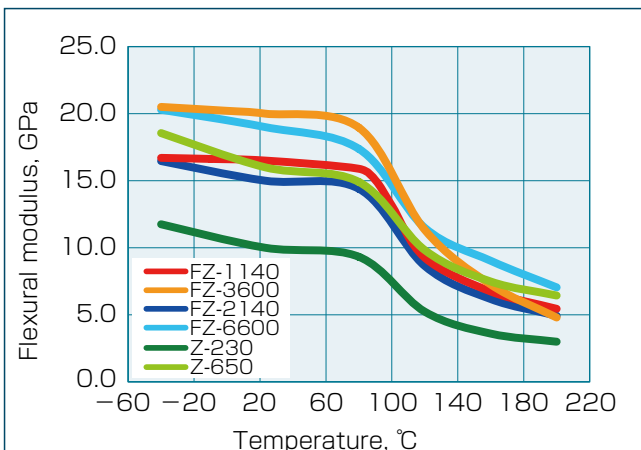

Fig.4.4 Effect of temperature on flexural modulus

strength and modulus at room temperature. Moreover, the branched grade FZ-1140 shows higher rigidity than that of the linear grade FZ-2140.

As shown in Figure 4.5, the flexural elongation at break is temperature dependent and increases at temperatures higher than T_g.

Figure 4.6 and Table 4.1 show the temperature dependence of compressive strength and shear strength which is similar to the flexural and tensile properties.

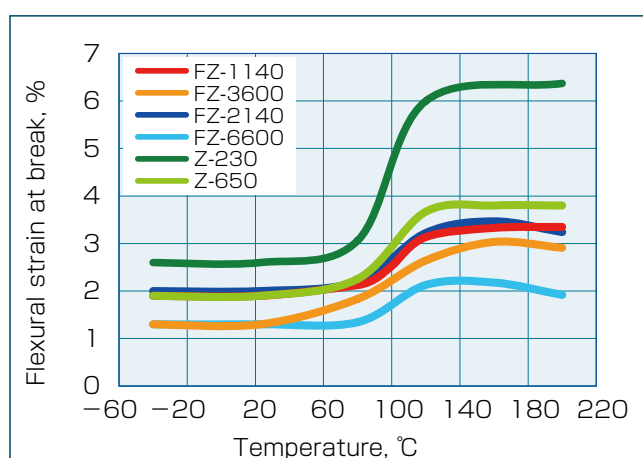

Fig.4.5 Effect of temperature on flexural elongation at break

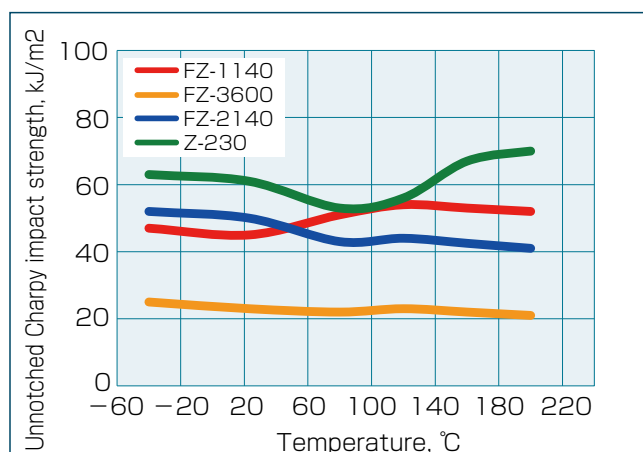

Fig.4.7 Effect of temperature on unnotched impact strength

Weld lines, one of the weak points of injection molded products, are unavoidable in most cases. Figure 4.8 shows how the weld tensile strength is affected by different temperatures. Super tough grades and linear polymer-based grades have better weld strengths at temperatures above 120°C when compared to branched polymer-based grades.

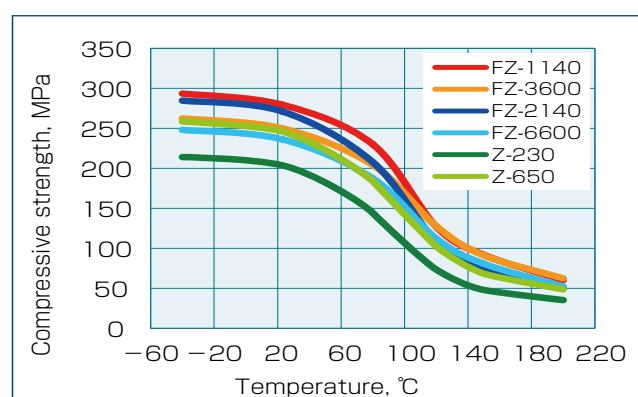

Fig.4.6 Effect of temperature on compressive strength

Table 4.1 Shear strength depending on temperature

	23°C	80°C	120°C	160°C
FZ-1140	88 MPa	85 MPa	56 MPa	40 MPa
FZ-2140	90 MPa	86 MPa	50 MPa	36 MPa
FZ-3600	85 MPa	82 MPa	52 MPa	38 MPa
FZ-6600	90 MPa	85 MPa	54 MPa	38 MPa

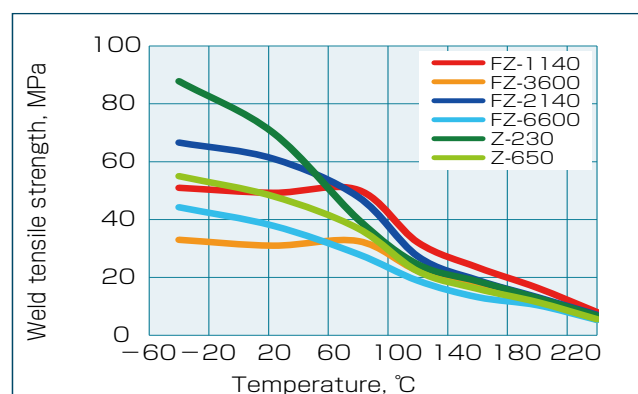

Fig.4.8 Effect of temperature on weld tensile strength

4.2. Anisotropy of Mechanical Properties

All plastic materials reinforced with rigid fibers such as GF exhibit material anisotropy whose properties are governed by the orientation of the fibers during molding. In the case of PPS, due to its semi-crystalline structure, the orientation of the molecule further increases the material anisotropy.

The extent of anisotropy depends on molding wall thickness, molding conditions and gate shapes in the molded products. Characteristics which are influenced by anisotropy are the mechanical behaviors like strength, modulus and elongation at break as well as the dimensional properties like mold shrinkage and linear thermal expansion. The heat distortion temperature is also affected as well.

In this section, the anisotropy is explained in line with the mechanical properties. For convenience, the direction of fiber orientation, for instance the flow direction, is abbreviated as FD (Flow direction: "1" in the coordinate axis) and the direction vertical to it is abbreviated as TD (Transverse direction: "2" in the coordinate axis) as shown in Figure 4.9.

The flexural properties are shown in Figure 4.10 for strength, Figure 4.11 for modulus, and Figure 4.12 for strain (elongation) at break. In this way, the flexural strength and flexural modulus in the TD are less than half of those in the FD described in section 4.1.

Therefore, for molded products with a clear orientation of fibers, special care must be taken in the same way as with weld lines.

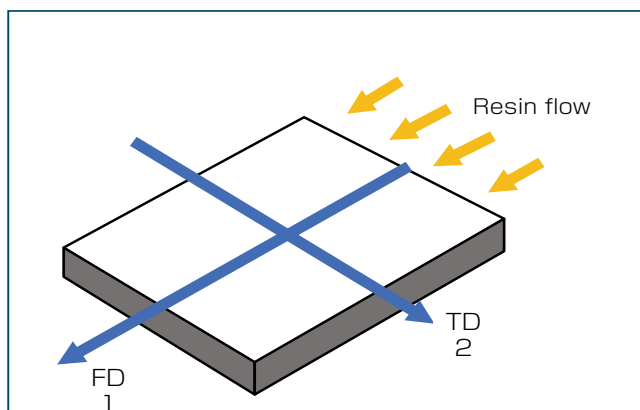

Fig.4.9 Flow directions and the co-ordinate system

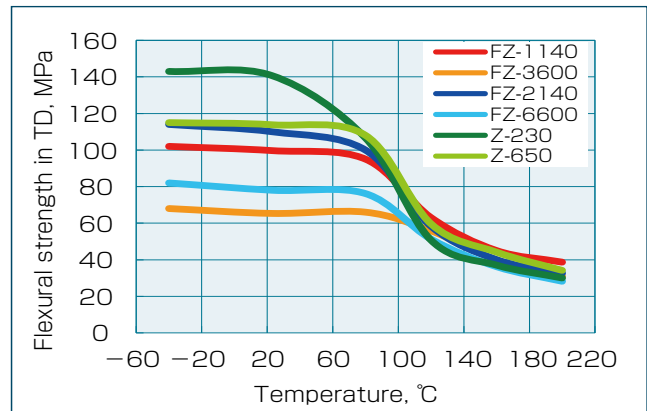

Fig.4.10 Flexural strength in TD as a function of temperature

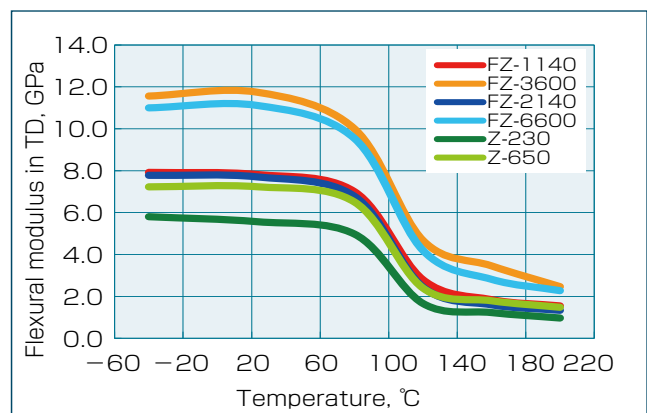

Fig.4.11 Flexural modulus in TD as a function of temperature

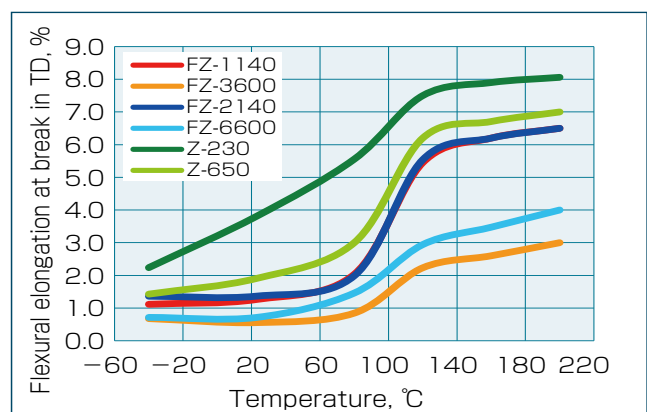

Fig.4.12 Flexural elongation at break in TD as a function of temperature

As indicated in these figures, super-tough grades (Z-230, Z-650) or GF reinforced grades (FZ-1140, FZ-2140) showed superior strength and strain (elongation) in the TD, while GF and mineral filler filled grades (FZ-3600, FZ-6600) showed higher rigidity.

At temperatures above T_g , the differences of flexural strength in TD is smaller. Anisotropic Charpy impact

Table 4.2 Anisotropy of Charpy impact strength (TD/FD, 23°C)

Grade	Notched	Unnotched
FZ-1140 BLACK	0.8	0.7
FZ-2140 BLACK	0.8	0.6
Z-230 BLACK	0.9	0.9

strength of each grade is shown in Table 4.2. Super-tough grade, Z-230 tends to have less dependence on fiber orientation.

Figure 4.13 shows the temperature dependence of Poisson's ratio when strength is applied in the FD. Poisson's ratio is inclined to increase with increasing temperature.

4.3. Long Term Mechanical Properties

Most plastic molded products face problems such as increased strain (creep) when a constant external force is applied or decaying stress (stress relaxation) when a constant strain is applied to the molded product. One distinct feature of PPS is that these changes are little.

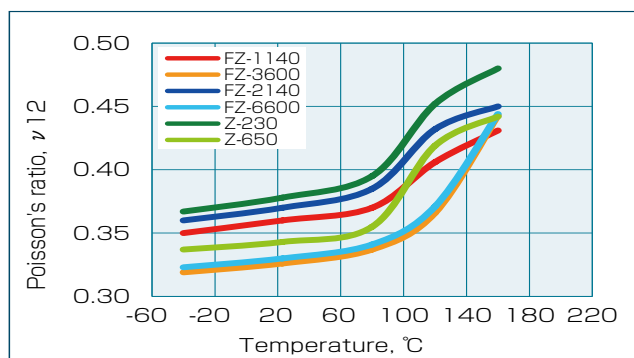

Fig.4.13 Effect of temperature on Poisson's ratio

However, the degree of creep and stress relaxation of PPS are dependent on temperatures.

The flexural creep and short-term compressive stress relaxation properties are shown in Figures 4.14, 4.15, 4.16 and 4.17, respectively. These data indicate that branched PPS compound has better creep resistance and stress relaxation resistance properties in comparison with super tough and linear PPS compounds. This phenomenon is

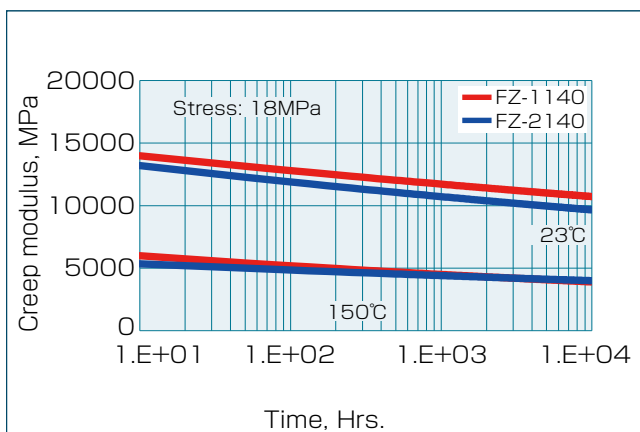

Fig.4.14 Flexural creep modulus of tough GF40% grades affected by temperature

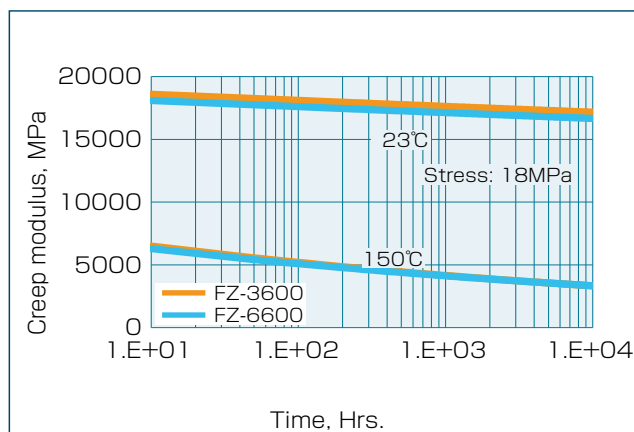

Fig.4.15 Flexural creep modulus GF/Filler grades affected by temperature

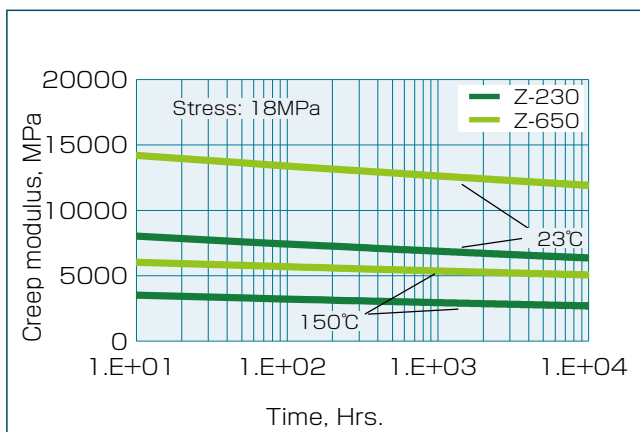

Fig.4.16 Flexural creep modulus of tough "Z" grades affected by temperature

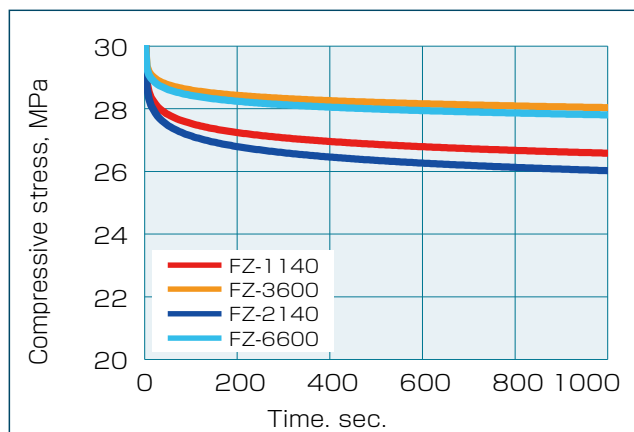

Fig.4.17 Short term stress relaxation in thickness direction at 120°C under compressive stress

also substantiated by the difference in the characteristics of visco-flexurality of PPS polymers between linear and branched PPS polymers, shown in Table 2.1. PPS molded parts can withstand the prolonged application of high dynamic or cyclic loads. In such cases, the fatigue characteristics should be taken into consideration for the molding design. The fatigue limit is defined as the maximum stress at which failure occurs as the amount of

cycles becomes very large (10^7 repetitive cycles). From experience, the fatigue strength of PPS is about 20 to 25% of the static strength measured under the same environment and conditions. Figures 4.18, 4.19 and 4.20 demonstrate the results of fatigue tests under constant stress based on ISO standard in the form of flexural fatigue S-N curves. The flexural fatigue limit in varying environmental temperatures is also shown in Table 4.3.

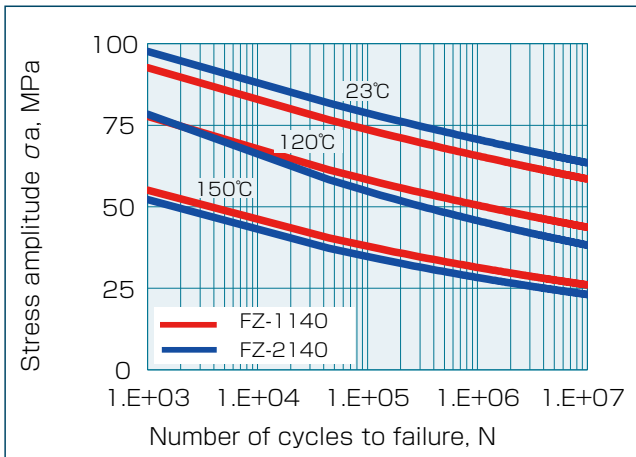

Fig.4.18 Flexral S-N curves of GF40% grades

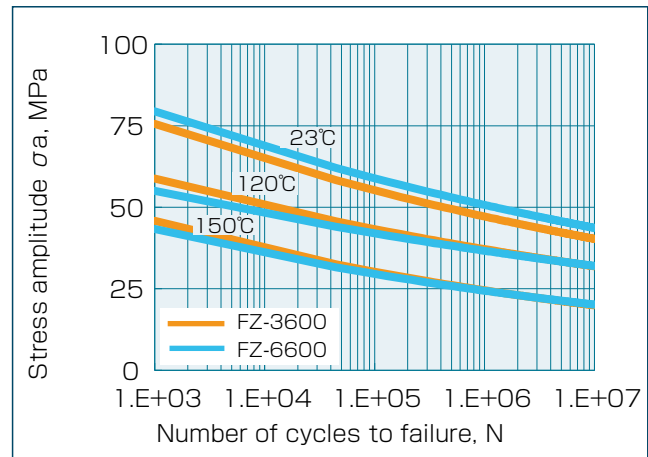

Fig.4.19 Flexral S-N curves of GF/filler grades

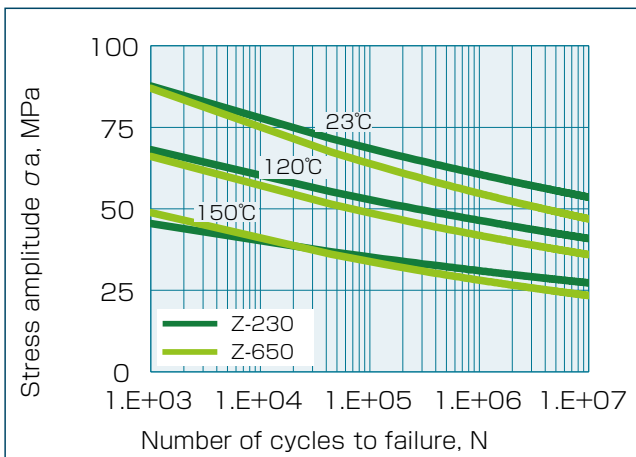

Fig.4.20 Flexral S-N curves of tough "Z" grades

Table 4.3 Flexural fatigue endurences in 10^7 cycles

	23°C	120°C	150°C
FZ-1140	58 MPa	40 MPa	26 MPa
FZ-2140	63 MPa	36 MPa	24 MPa
FZ-3600	40 MPa	32 MPa	20 MPa
FZ-6600	44 MPa	32 MPa	20 MPa
Z-230	56 MPa	42 MPa	27 MPa
Z-650	48 MPa	37 MPa	23 MPa

4.4. Thermal Properties

4.4.1. Linear Thermal Expansion

Similar to its mechanical properties, the linear thermal expansion coefficient of PPS is anisotropic. Figure 4.21 shows the linear thermal expansion coefficient curves in the FD and TD when the orientation is strong. If the orientation is unclear, the median value between the FD and TD is used. The coefficient of linear thermal expansion of fiber reinforced DIC.PPS can reach 2.4×10^{-5} m/mK, the same level as aluminum die-cast.

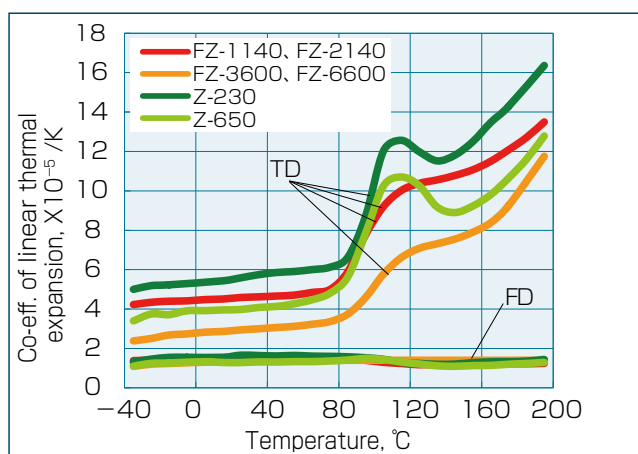

Fig.4.21 Thermal expansion curves as a function of temperature

Table 4.4 Continuous use service temperatures(°C)

Grade	Thickness (mm)	Electrical	Mechanical	
			With impact	Without impact
FZ-1140 & FZ-1140-XY	0.75	200	200	200
	1.5	220	200	220
	3.0	220	200	220
FZ-3600 & FZ-3600-XY	0.73	240	200	220
	1.5	240	200	220
	3.0	240	220	240
FZ-2140 & FZ-2140-XY	0.75	200	200	200
	1.5	220	200	220
	3.0	220	200	220
FZ-6600 & FZ-6600-XY	0.73	240	200	220
	1.5	240	200	220
	3.0	240	220	240

Suffix X : One letter selected from A to Z and suffix Y : One digit selected from 0 to 9.

4.4.2. Long Term Heat Aging Properties

PPS is exceptionally good in terms of heat resistance and durability compared to other engineering plastics. The relative temperature index (RTI) shown in Table 4.4 is above 200°C. Table 4.5 shows the heat resistance stability of a PPS disk with a diameter of 50 mm and a thickness of 2 mm. Figure 4.22 shows the strength and impact properties of the thermal degradation characteristics. When exposed to high temperatures above 200°C in the presence of oxygen, physical properties decrease and discoloration progresses. These changes become more prominent at higher temperatures and when time advances.

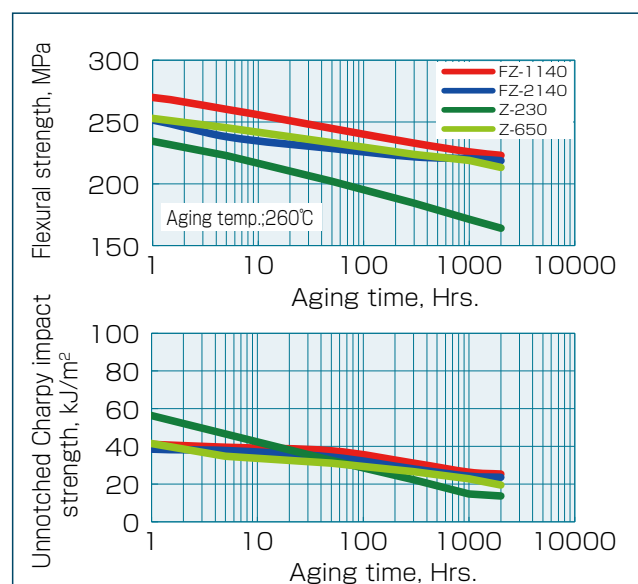

Fig.4.22 Heat aging degradation of mechanical properties

Table 4.5 Heat aging dimensional stability of FZ-1140 using $\Phi 50\text{mm} \times 2\text{mm}$ disc molding with pin gate

Aging condition		Dimensional change,%
150°C	5Hrs.	-0.01
	100Hrs.	-0.02
	1000Hrs.	-0.03
230°C	5Hrs.	-0.07
	100Hrs.	-0.11
	1000Hrs.	-0.13

4.4.3. Thermal Conductivity

Thermal conductivity is defined as the rate at which heat flows through materials in steady state. Figure 4.23 shows the thermal conductivities measured by the hot disk method and laser flash method. Since PPS polymer, GF, and inorganic fillers have their respective thermal conductivities, the thermal conductivity of mixed compounds depend on their composition. In addition, thermal conductivity tends to increase when the thickness of molded product increases. Furthermore, the orientation of the reinforced fibers also affects the thermal conductivity.

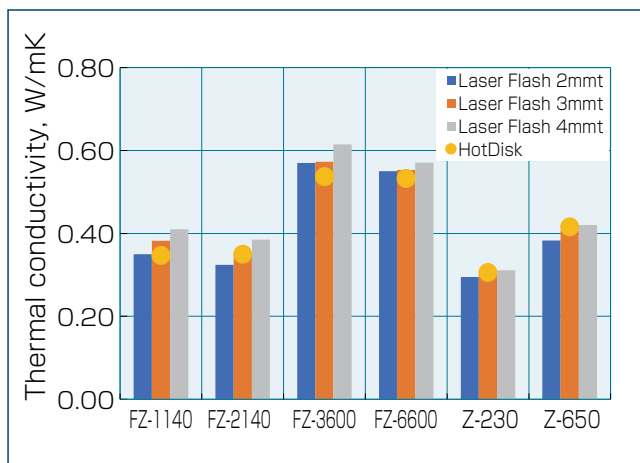

Fig.4.23 Thermal conductivity as a function of thickness

4.4.4. Specific Heat

Specific heat is defined as the amount of heat needed to raise the temperature of a substance per unit mass, at constant pressure. It changes with temperature. Figure 4.24 shows the temperature dependence of specific heat.

4.4.5. Thermal Diffusivity

Thermal diffusivity, λ is defined as the rate at which a material with a non-uniform temperature approaches equilibrium. It is expressed as $\lambda = \text{thermal conductivity} / (\text{specific heat} \times \text{density})$. High diffusivity means that heat transfers rapidly, therefore it can be an indicator of material's ease to cool down.

FZ-1140 and FZ-2140 are slower to cool down and solidify when compared with FZ-3600 and FZ-6600, resulting in higher fluidity and are suitable for thin wall moldings.

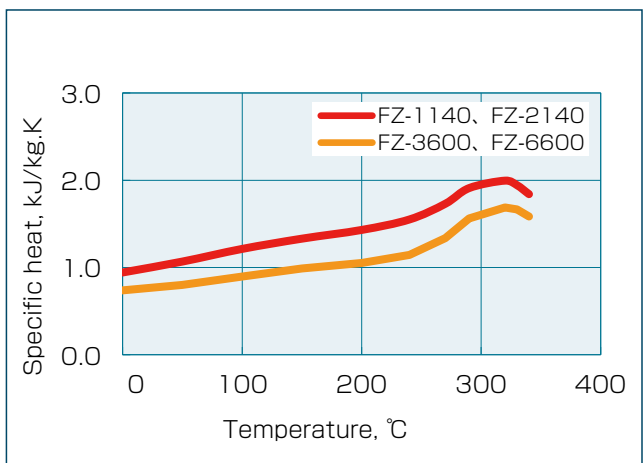

Fig.4.24 Specific heat as a function of temperature

4.4.6. PVT Curves

PVT data represents the correlation of pressure (P), specific volume (V), and temperature (T). As shown in Figures 4.25 to 4.28, in the case of PPS, which is a crystalline resin, the specific volume changes suddenly around the melting point of 280°C. This

means the volume will decrease suddenly when the material solidifies. Volumetric shrinkage is one of the cause of warping deformation in crystalline resin molded products, and this data is used in computer simulated warping analysis.

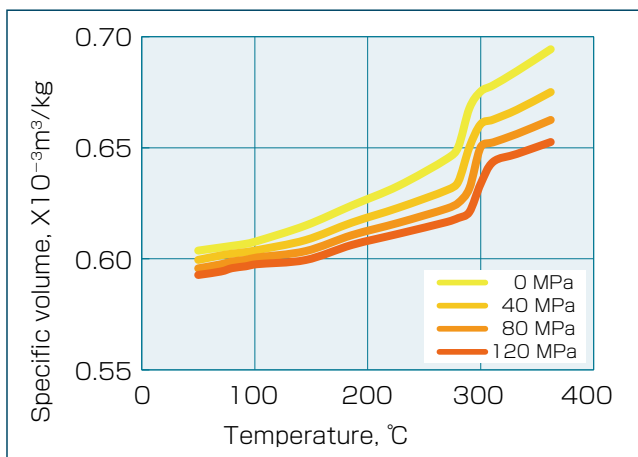

Fig.4.25 PVT diagram of FZ-1140 & FZ-2140

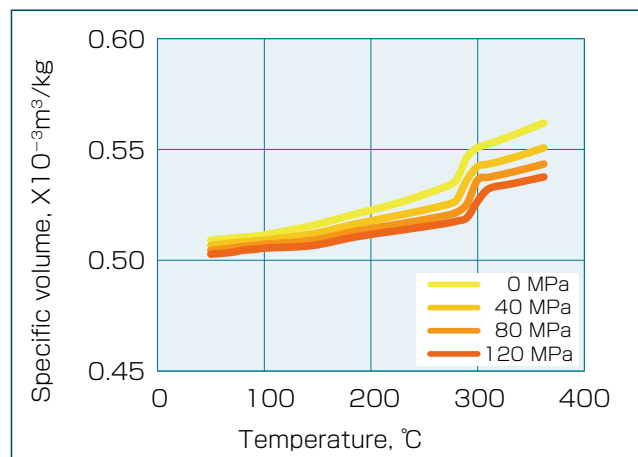

Fig.4.26 PVT diagram of FZ-3600 & FZ-6600

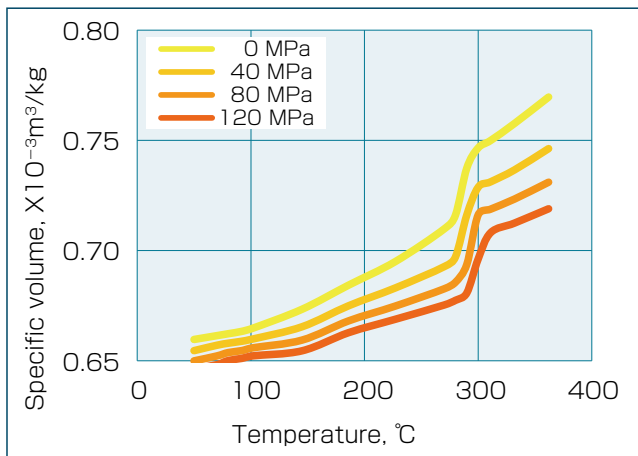

Fig.4.27 PVT diagram of Z-230

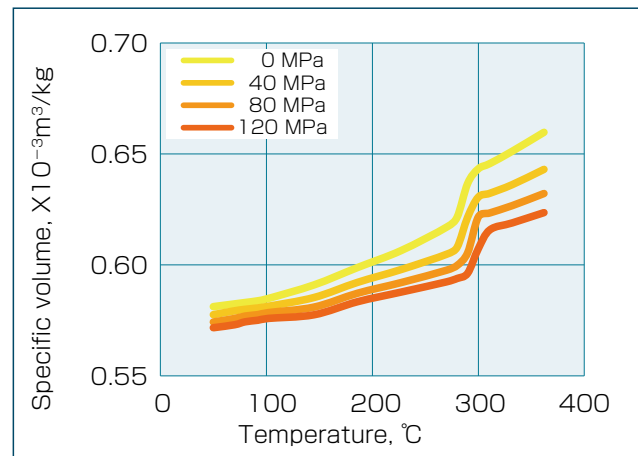

Fig.4.28 PVT diagram of Z-650

4.5. Electrical Properties

In general, electrical insulating properties are characterized by electric strength, volume resistivity, surface resistivity, relative permittivity, dissipation factor, arc resistance, tracking characteristics, etc. Electric strength is defined as the maximum voltage needed to cause dielectric breakdown through electrical insulating material. Materials are usually placed in insulating oil and the A.C. voltage is measured.

Although DIC.PPS possesses excellent insulating properties, such properties are highly dependent

of thickness as shown in Figure 4.29. The apparent electric strength tends to increase slightly with elevated temperature as shown in Figure 4.30.

Modern electronic circuits which are becoming increasingly more integrated and more miniaturized demand materials with better electric signal transmission. Among engineering plastics, electric constant and dissipation factor of DIC.PPS is low and relatively independent of frequency and temperature. These tendency can be seen in Figure 4.31.

Insulation resistivity is an indicator of electric insulating property. As shown in Figures 4.32 and

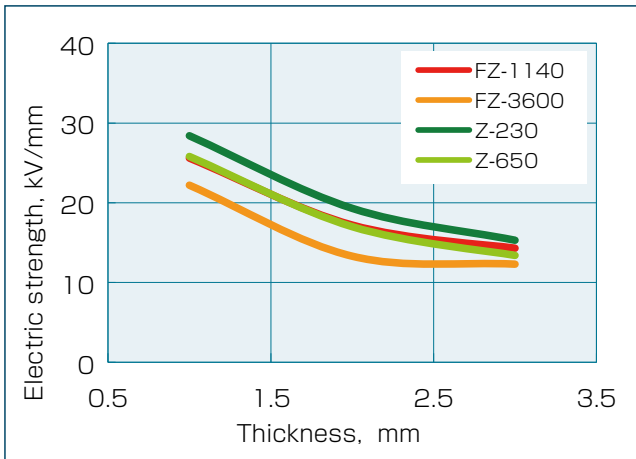

Fig.4.29 Electric strength depending on wall thickness

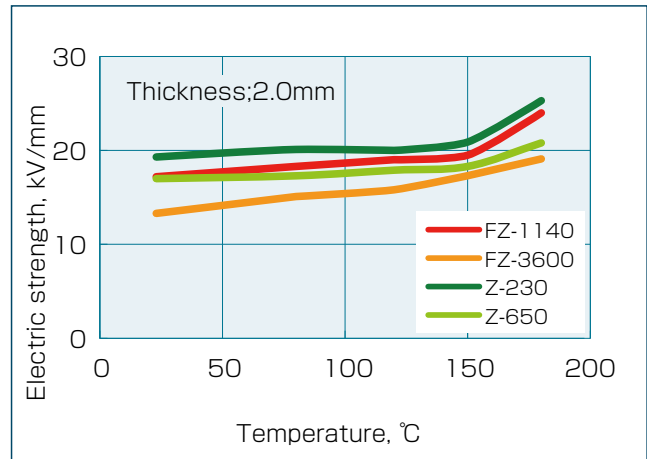

Fig.4.30 Electric strength of FZ-1140 depending on temperature

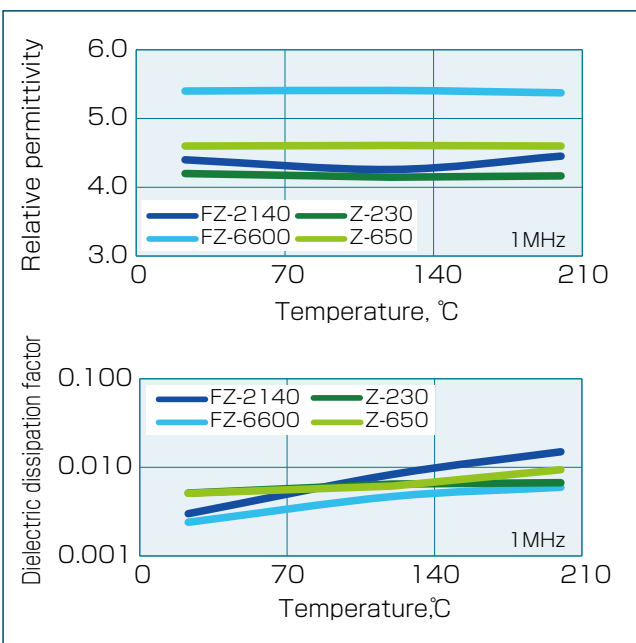

Fig.4.31 Effect of temperature on dielectric properties

4.33, due to the low water absorption of DIC.PPS, volumetric resistivity is not strongly affected by humidity and temperature when compared to other engineering plastics. FZ-2140 and FZ-6600 which are composed of high purity linear polymers, have lower water absorption and better insulation resistance than branched FZ-1140 and FZ-3600.

Dielectric loss is an energy deposition phenomenon that occurs when electromagnetic energy dissipates in insulating materials. Most of the energy is converted to heat, which causes the rise in temperature of the insulating materials. This dielectric loss is determined by the relative permittivity and the dielectric dissipation factor of material and is generally known to be frequency- and temperature-dependent. Among thermoplastics, DIC.PPS has low relative permittivity and low dielectric dissipation factor, and is influenced less by frequency and temperature. This characteristic is advantageous for PPS, which is used as a peripheral material, as recent electronic circuits in microwave ovens and computers become denser and smaller. Figure 4.31 shows the temperature-dependence data of dielectric properties.

Caution should be taken for the use of some DIC.PPS grades. For instance, the inorganic filler filled FZ-3600 and FZ-6600 series has a slightly higher dielectric loss than the 40% GF reinforced FZ-1140 and FZ-2140 series.

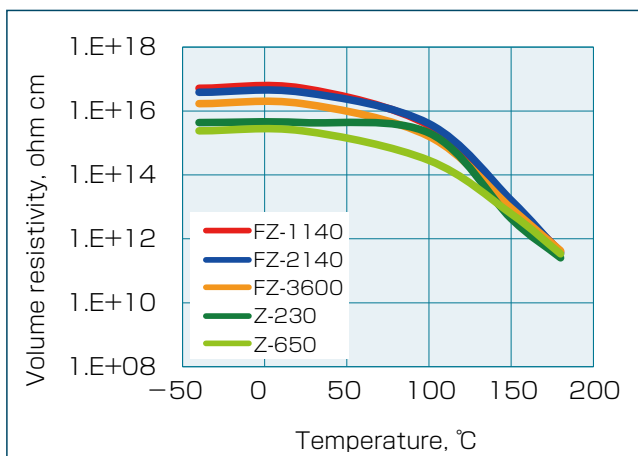

Fig.4.32 Temperature dependence of volume resistivity

Volume resistivity is another basic property indicating the characteristics of insulating materials. DIC.PPS is less hygroscopic than other engineering plastics, therefore it is mostly independent of temperature and humidity as shown in Figure 4.32 and Figure 4.33.

Dry arc resistance refers to the ability of an insulating material to resist surface tracking currents caused by high voltage electrical arc generated between two electrodes applied to the surface. It is usually expressed in terms of time. In the case of insulating materials, a minimum of 120 seconds is generally required to render them electrically conductive.

Based on ISO testing method, FZ-1140, FZ-2140, FZ-3600 and FZ-6600 have an arc resistance of over 120 seconds.

Resistance of surface tracking when the material surface is contaminated is indicated by the Comparative Tracking Index (CTI).

PPS polymer on its own is not particularly good in tracking resistance, but it can be improved by filling with special inorganic fillers.

Please refer to Datasheets for each grade for the arc resistance and CTI values.

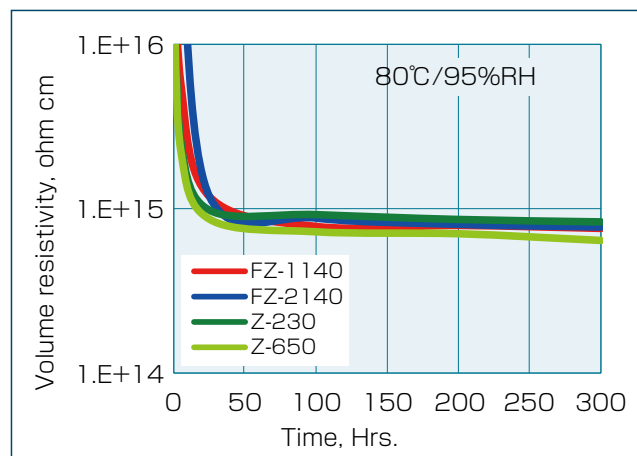

Fig.4.33 Change of volume resistivity by water absorption

4.6. Chemical Resistance

DIC.PPS has excellent resistance to a broad range of chemicals including strong acids, strong bases, organic solvents, fuels, motor oil and transmission fluids, at elevated temperatures. This is evidenced by the fact that DIC.PPS is unable to be chemically dissolved below temperatures under 200°C. However, it should be noted that strong acids such as concentrated nitric acid which are highly oxidative may cause deterioration in the material.

Furthermore, concentrated hydrochloric acid weakens the bonds between GF and PPS, resulting in the decline of mechanical properties of the compounds.

Table 4.6 shows the chemical resistance test results of FZ-1140, FZ-3600 and Z-230 immersed in various chemicals. The chemical resistance of FZ-2140 and FZ-6600 is the same as FZ-1140 and FZ-3600.

Table 4.6 Chemical resistance;Weight change, dimensional change and retention of flexural strength after 1000Hrs. immersed in chemicals

Substance	Temp.	FZ-1140				FZ-3600				Z-230			
		Weight Change %	Flexural strength Retention %	Dimention Change % FD TD		Weight Change %	Flexural strength Retention %	Dimention Change % FD TD		Weight Change %	Flexural strength Retention %	Dimention Change % FD TD	
H2SO4, 10%	23	-0.15	97	0.01	0.04	-1.72	83	0.02	0.03	-0.14	97	0.02	0.03
HCl, 10%	23	-0.35	84	0.02	0.03	-5.10	75	0.02	0.03	-0.10	97	0.01	0.02
HNO3, 10%	23	-0.08	92	0.03	0.04	-1.47	77	0.03	0.04	-0.06	97	0.02	0.02
NaOH, 10%	23	0.14	90	0.03	0.05	0.23	68	0.04	0.07	0.08	96	0.03	0.03
NaCl, 10%	23	0.13	101	0.05	0.04	0.11	93	0.06	0.07	0.10	97	0.01	0.03
	80	0.33	75	0.06	0.10	0.27	82	0.07	0.11	0.15	73	0.02	0.07
CaCl2, 10%	23	0.14	97	0.02	0.04	0.14	93	0.06	0.08	0.11	99	0.02	0.02
	80	0.38	76	0.06	0.10	0.28	82	0.07	0.12	0.17	72	0.03	0.09
Methanol	23	0.20	105	0.02	0.04	0.11	102	0.02	0.06	0.36	101	0.05	0.08
Toluene	23	0.13	101	0.02	0.03	0.05	100	0.02	0.05	0.30	100	0.05	0.07
Motor oil	100	0.07	98	0.03	0.05	0.02	106	0.03	0.05	0.11	103	0.05	0.07
ATF	160	0.24	102	0.04	0.09	0.15	103	0.04	0.07	0.36	100	0.05	0.10
LLC, 50%	140	0.41	80	0.07	0.13	0.65	75	0.10	0.21	0.34	84	0.05	0.08
Gasoline	23	0.07	101	0.01	0.02	0.07	102	0.01	0.03	0.06	100	0.01	0.02
Light oil	23	0.06	101	0.02	0.03	0.02	102	0.02	0.04	0.05	101	0.01	0.02
	80	0.04	102	0.02	0.02	0.01	104	0.02	0.03	0.07	102	0.02	0.07

4.7. Resistance to Hot & Wet Conditions

DIC.PPS has extremely low water absorption. This characteristic indicates that it is not easily affected by high humidity environments. However, some moisture absorption is observed under high temperature and high humidity, therefore certain precautions must be taken depending on the application. Figure 4.34 and Table 4.7 show the correlation between moisture absorption and time of a 2mm thick sheet under 60°C/95% RH, 85°C/95% RH and PCT (121°C/2.2atm) conditions. FZ-2140 and FZ-6600 which are high purity linear PPS compounds absorb less moisture than FZ-1140 and FZ-3600 which are branched PPS

compounds.

On the other hand, dimensional changes due to moisture absorption correlate with the amount of absorbed moisture, regardless of the moisture absorption conditions. Similar to the dimensional changes, strength reduction due to moisture absorption also depends on the amount of absorbed moisture. Figure 4.35 shows the relationship between tensile strength and time under conditions of 85°C/95% RH and PCT (121°C/2.2atm).

Moisture absorption also affects the electrical characteristics, for more details please refer “4.5 Electrical properties”

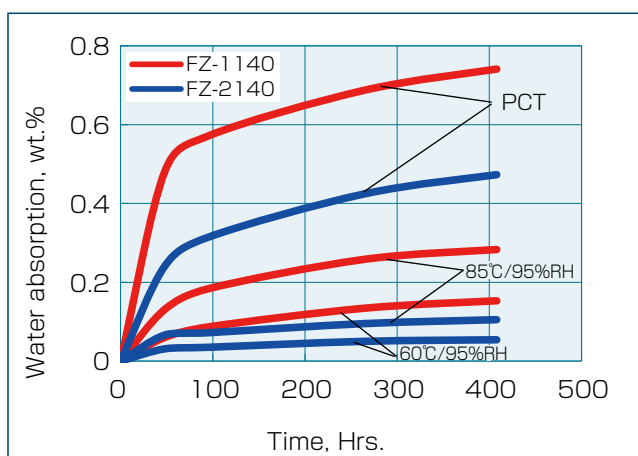

Fig.4.34 Water absorption under hot and wet conditions

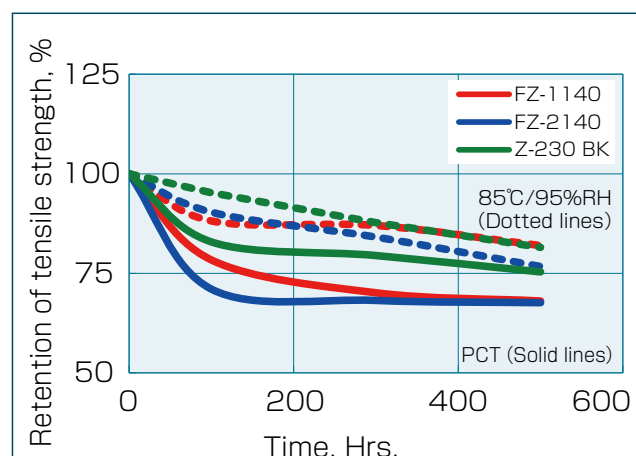

Fig.4.35 Changes of strength under hot and wet conditions

Table 4.7 Water absorption by weight % after 500 Hrs

Conditions	FZ-3600	FZ-6600
85°C /95%RH	0.34%	0.18%
121°C Pressure cooker test	0.55	0.45

5. OTHER PROPERTIES

5.1. Environmental Resistance

As for DIC.PPS, peeling due to micro cracks, discoloration and deterioration on the surface of molded products during weather testing is recognized. However, as shown in Figure 5.1, there is only little degradation of mechanical properties.

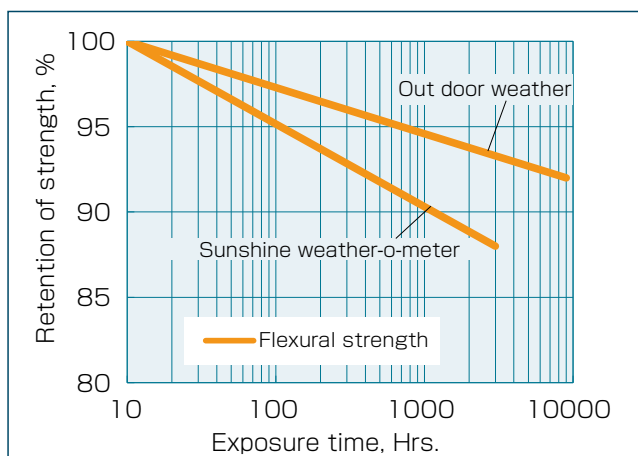

Fig.5.1 Weather resistance of FZ-1140

5.2. Abrasion Resistance

Abrasion resistance, measured by the Taber abrasion tester, is indicated by the amount of wear when in contact with an abrasive substance. On the other hand, sliding friction of a plastic material mounted on a steel rotary cylinder can be measured using the method shown in Figure 5.2. Both the properties of wear and sliding friction data are summarized in Table 5.1

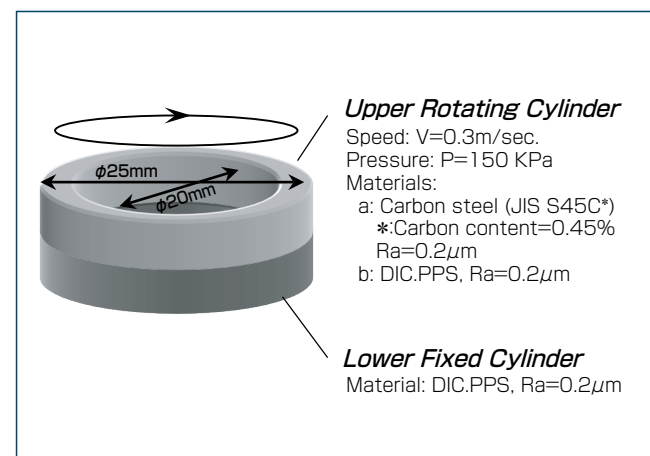

Fig.5.2 Test method for the sliding frictional properties.

Table 5.1 Abrasion and frictional properties

Conditions	FZ-3600	FZ-6600
Taber/Taber abrasion mg/1000 cycles (CS-17)	60	72
Co-efficient of friction DIC.PPS vs. steel		
Dynamic	0.35	0.35
Static	0.35	0.35
DIC.PPS vs. DIC.PPS		
Dynamic	0.44	0.42
Static	0.46	0.43

5.3. Hardness

Rockwell hardness of DIC.PPS representative grades are shown in Table 5.2. Hardness of DIC.PPS depends on the polymer type, the type and amount of reinforcement materials. Additionally, hardness has a strong correlation with the crystallinity of PPS. The higher the crystallinity, the harder the material becomes. For more details of the correlation between mold temperature and Rockwell hardness, refer to the “Molding conditions and physical properties” section.

Table 5.2 Rockwell hardness

	FZ-1140	FZ-2140	FZ-3600	FZ-6600	Z-230	Z-650
Rockwell						
M scale	101	94	98	97	81	89
R scale	123	122	121	121	118	118

	FZ-1140	FZ-2140	FZ-3600	FZ-6600	Z-230	Z-650
Rockwell						
M scale	100	100	100	100	85	90
R scale	121	121	121	121	116	118

5.4. Limiting Oxygen Index

Limiting oxygen index (LOI) is an indicator of flammability. It is defined as the minimum concentration of oxygen, in admixture with nitrogen, needed for the test piece to continue burning under specified test conditions.

Table 5.3 compares the LOI of DIC.PPS with other plastics, measured using the ISO method. These values indicate that DIC.PPS is superior in fire retardancy compared with other plastics.

Table 5.3 Limiting oxygen indexes of DIC.PPS and Others

Materials	Limiting oxygen index
DIC.PPS FZ-1140, FZ-2140	47
DIC.PPS FZ-3600, FZ-6600	53
PES GF30	41
LCP GF30	
G.P. grade	35
Heat resistant grade	47
PBT GF30 (FR grade)	33
Nylon-66	28
Modified PPE (FR grade)	30
Polycarbonate (FR grade)	34
POM	16
PTFE	95
Polyolefines	18
PVC	48

6. MOLDING PROCESS

The following points should be noted when using DIC.PPS.

6.1. Prior Preparation Before Injection Molding

6.1.1. Molding Machine

Any conventional injection molding machine can be used. Anti-wear screw, cylinder and mold for GF or mineral filled compounds are recommended to alleviate machine and mold wear. Normally, open nozzle with backflow prevention ring is used. In addition, the use of abrasion resistant shut-off nozzle is effective when high precision molding is needed.

6.1.2. Drying

Although DIC.PPS has low moisture absorption, pre-drying prior to molding is needed to maintain stable production and quality of molded parts. Drying should be conducted in the following conditions,

- 120°C: 4-6 hours,
- 130°C: 3-5 hours or
- 140°C: 2-3 hours.

6.2 Molding Conditions

The standard molding condition for DIC.PPS is shown in Figure 6.1. Due to PPS's relatively low melt viscosity, flashes tend to be generated easily. Flashes are highly dependent of molding pressure, and it can be improved by setting higher cylinder temperature while minimizing the injection pressure.

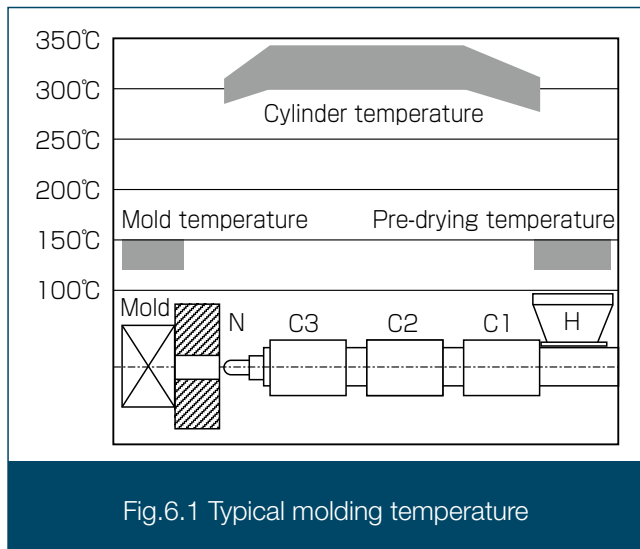

6.2.1 Cylinder Temperature

Cylinder temperature for molding PPS is usually set to be around 300-340°C. However, the super tough DIC.PPS (Z-230, Z-650) and the fluorine resin added grades should have lower temperatures set at 290-320°C. If the temperature on the hopper side is lower than necessary, unmelted pellets may accelerate the wear of screws and cylinders. On the other hand, the nozzle temperature's setting is slightly lower than the central part of the cylinder to prevent the resin from excessive drooling.

6.2.2. Mold Temperature

Mold temperature is varied widely, ranging from room temperature to over 150°C. However, it should be noted that characteristics of PPS vary greatly depending on the mold temperature. To maximize the performance of PPS, it is necessary to ensure sufficient crystallinity. Therefore, the recommended mold temperature range is 130-150°C. High mold temperatures will improve the crystallinity, surface smoothness and glossiness of moldings. On the other hand, when the mold tempera-

ture is less than 130°C, crystallization of the molded product becomes insufficient. This may cause molding problems such as poor surface condition, release ability, dimensional stability and discoloration. It also affects various properties such as molding shrinkage, mechanical properties, and heat resistance. If the use of low temperature molds is unavoidable, avoid temperatures near Tg (90 ± 10°C) because the mold release property is poor.

6.2.3. Injection Speed

Injection speed is usually determined by the appearance of the molded product. High speed is suitable for obtaining a good appearance but there is a risk of warping and gas burning of the molded product. The filling time is usually set at 0.5 to 1.5 seconds.

6.2.4. Injection and Holding Pressure

Injection pressure is roughly divided into filling pressure and holding pressure. Holding pressure after filling the cavity plays an important role. In general, holding pressure of 50MPa is enough. Increasing the holding pressure is effective in resolving problems like sink and void, but when in excessive, it may cause flashes.

6.2.5 Rotation Speed and Back Pressure

Screw rotation speed is usually set at 40-150rpm. If the rotational speed is too high, the GF, which is a reinforcing fiber material, may be damaged in excess and the material strength may be reduced.

The back pressure is usually about 1-2MPa. However, if the metering is unstable, which may result in short shots, the back pressure can be increased to 3-4MPa.

6.2.6. Purging

It is recommended to clean or purge the cylinder of the molding machine by using high viscosity resin materials like blow molding grade polyethylene. Commercially available acrylic cleaning materials can also be used.

6.3. Recycling

DIC.PPS is an engineering plastic that has little polymer molecular weight degradation and material deterioration during molding. Therefore, recycling of sprues and runners is possible. However, there are three important points during recycling.

Firstly, the recycled material itself must be of materials that have undergone normal molding processes. Secondly, grinded recycled material must have uniform particle size by passing through sieves. This will remove the presence of grinded powder which inhibits molding stability. Thirdly, if the molded product is used for electrical insulating purposes, the recycled material has to be passed through a strong magnet (9000 Gauss etc.) for the

through removal of metal powder generated by the grinder.

In general, the recycled material ratio is determined after checking the quality of the molded product. However, the amount of recycled materials is recommended to be less than 30%. Figures 6.2 to 6.4 show the changes in flexural strength, impact strength, and flowability when the recycled material is added at 30, 50, and 100%. These changes in properties after using recycled material are mainly due to the change in length of the GF used for reinforcement after the regrinding. As reference, Table 6.1 shows the results of FZ-1140. The same tendency shown by FZ-1140 also applies to the other types and grades of DIC.PPS.

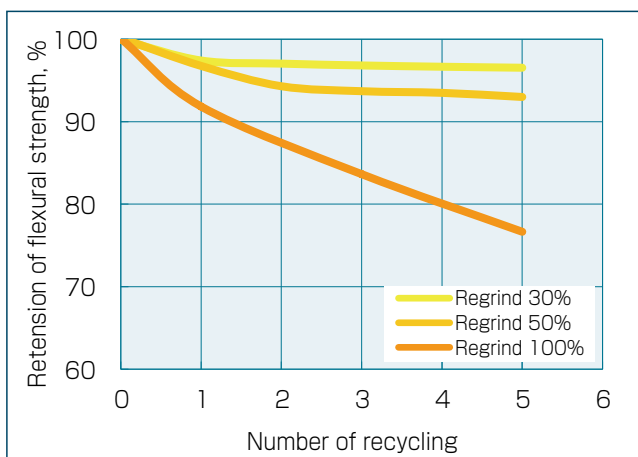

Fig.6.2 Change of flexural strength by recycling

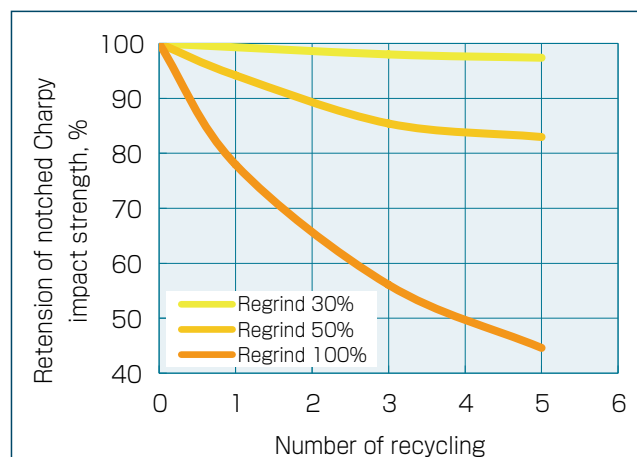

Fig.6.3 Change of impact strength by recycling

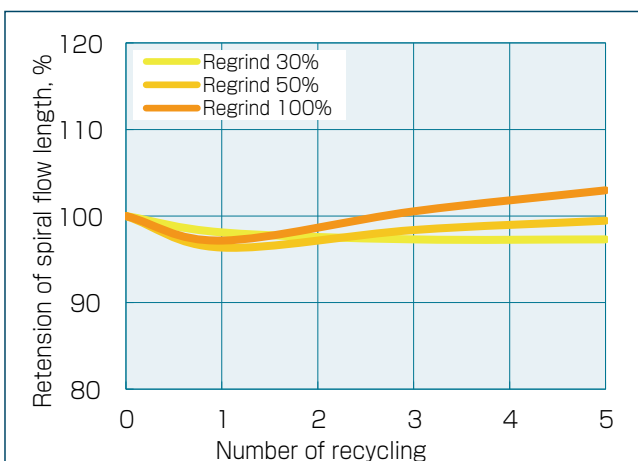

Fig.6.4 Change of flowability by recycling

Table 6.1 Change of glass fiber length by recycling (Regrind 100%)

Number of recycling	0	1	3	5
Average fiber length, μ m	250	210	200	190

6.4. Mold Design

6.4.1. Mold Material

High alloy steel with excellent corrosion resistance and wear resistance is recommended for PPS molds. For example, SKD-11 specified in JIS is the most common steel material. In addition, stainless steel of the SKD-61, SUS420, and SUS440 series can also be used. The Rockwell hardness for the steel material after quenching should be R55 or higher, preferably R60. Furthermore, it is economical to use a wear resistant material such as tungsten carbide or titanium carbide in the nesting system for parts that are particularly easily worn, such as gates. Moreover, surface hardening treatments such as ion plating and ceramic coating are also effective in improving the durability of the mold.

6.4.2. Temperature Control

Cartridge heaters or heated oil are usually used for heat control of the mold. Regardless of the heating method, to prevent the heat transfer between the mold and molding machine, insulation materials should be placed between the mold and platens. Laminated phenolic board is a good example of materials used for heat insulation.

6.4.3. Runner and Sprue

In general, full-round and trapezoidal runner designs are used. Half-round and square runner designs are not recommended. A cold slug well must be provided at the end of the runner and sprue. As for sprue design, a standard round shaped sprue is sufficient.

Hot runner system can also be used for DIC.PPS, but it is necessary to select a system that has highly precise temperature control and sufficient wear resistance for the nozzle tip.

6.4.4. Gating

Gate types such as side, film, disk, center, tunnel, pin-point and submarine gate are usable, but side gate is the most popular gate type for PPS.

Film gate in general is effective for flat designs of large

area where warpage must be avoided at best, whereas disk gate is effective in ensuring the roundness of round or cylinder shaped parts. Automatically trimmed gates like the submarine gate and tunnel gate are efficient because they do not require gate removal as a secondary operation. However, since PPS compounds are rigid there are limitations to the design of submarine gates. Figure 6.5 shows the specifics of a submarine gate design.

6.4.5. Draft Angles for Molds

Although it depends greatly on the polishing accuracy of the mold, in general, a molded product with a cavity depth of 10-50mm requires a draft angle of about 0.5 degrees on one side. However, for cavities with a depth of 10 mm or less, molding is possible at around 0.25 degrees. If the cavity depth is 50mm or more, a draft angle of 1 degree is required

6.4.6. Air Venting

Air vent (gas vent) is required for DIC.PPS molds. In general, the depth is about 0.005 to 0.008mm and the width is about 5mm. If the depth is 0.008mm or more, flashes may occur, and if it is 0.005mm or less, the effect of vent will be reduced, meaning mold defects like burning or non-uniform fill will occur more easily. In addition, air vent around the ejector pin is not recommended because the clearance may be clogged.

The vacuum vent system is effective for mold designs when the conventional venting methods is insufficient to displace air in the cavity. It is especially effective for molding processes that require high precision.

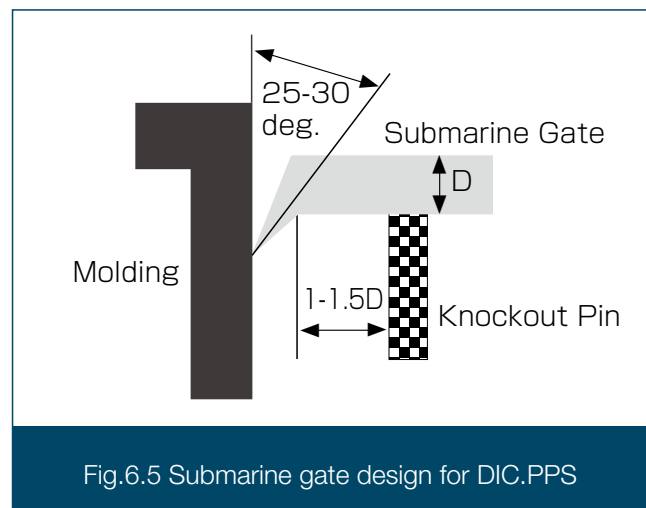

6.5. Mold Shrinkage

The shrinkage of reinforced and filled PPS is considerably small when compared to other resins. However, anisotropy due to semi-crystallinity and the reinforcing GF causes the PPS moldings to have different degrees of shrinkage in different directions. This may result in bigger warpage when compared to amorphous resins such as polycarbonate.

Although shrinkage and warpage are affected by various factors such as flowability, wall thickness, gate shape, mold temperature and molding conditions including resin temperature, the most important factors are the mold temperature and wall thickness. Furthermore, since they are also affected by the type and amount of reinforcing materi-

als and fillers, selecting an appropriate DIC.PPS grade is recommended.

Figure 6.6 shows the effect of mold temperature on shrinkage when the shrinkage anisotropy of a 60x60x2mm sheet with a film gate is extremely large.

Figure 6.7 shows the effect of wall thickness on shrinkage. The data is based on cases where the anisotropy of shrinkage is large. For example, in the case of pinpoint gates, the orientation of GF and molecules is weak and the anisotropy is not significant. In such cases, the shrinkage rate is the median of the flow direction (FD) and transverse direction (TD) as shown in Figures 6.6 and 6.7.

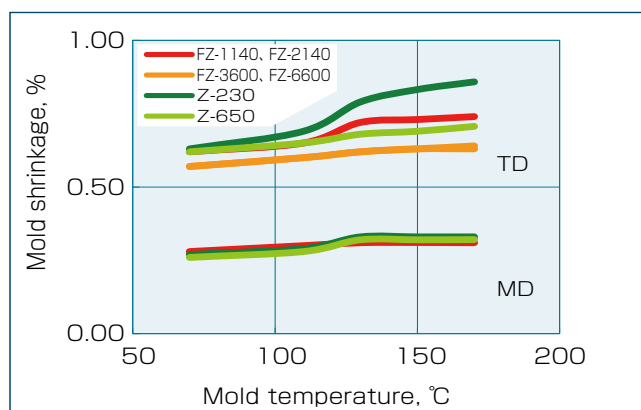

Fig.6.6 Effect of mold temperature on mold shrinkage

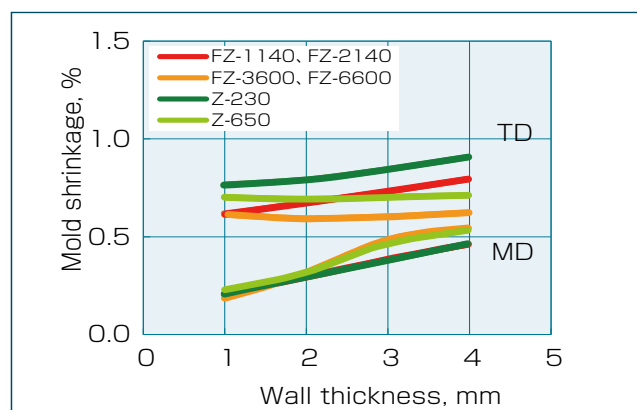

Fig.6.7 Effect of wall thickness on mold shrinkage

6.6. Flowability

Most DIC.PPS grades are highly filled with reinforcing materials and/or inorganic fillers. And the total ratio of the fillers might be 70% or more by weight, which shows that the flowability of PPS

Polymer is comparatively higher.

Figures 6.8 and 6.9 show the relationship between flow length measured by bar flow and molding conditions. The flowability is greatly influenced by the injection pressure and the resin temperature, but affected less by the mold temperature.

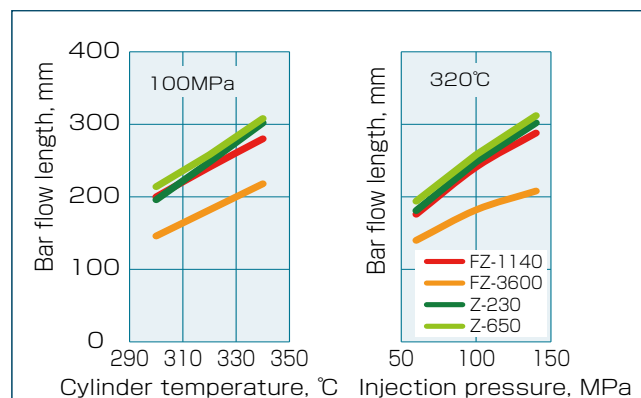

Fig.6.8 Flowability affected by cylinder temperature and injection pressure

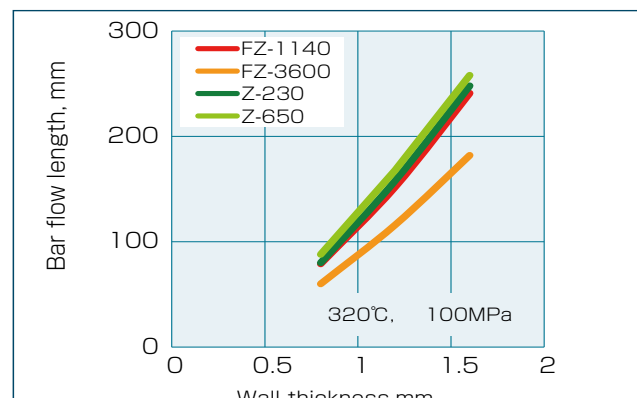

Fig.6.9 Flowability depending on wall thickness

The shear rate dependence of melt viscosity is shown in Figures 6.10-6.15. These data are also used in computer aided mold flow simulation.

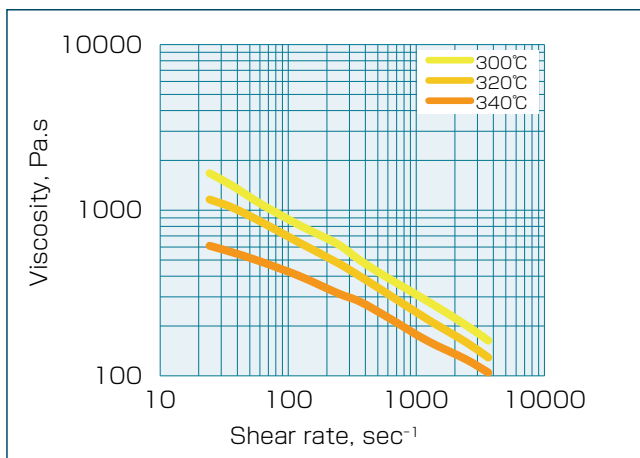

Fig.6.10 Melt viscosity of FZ-1140 dependent on shear rate

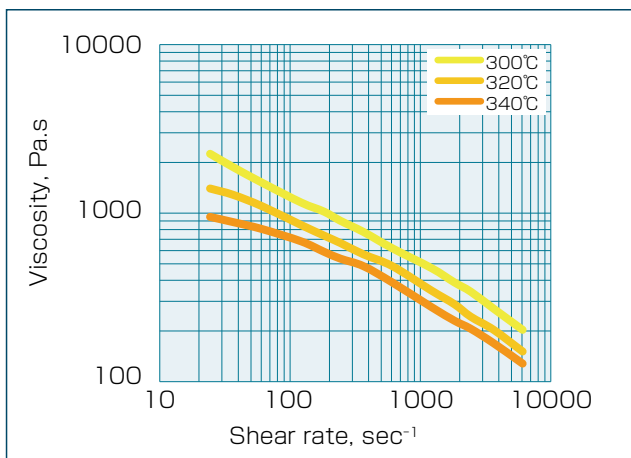

Fig.6.11 Melt viscosity of FZ-2140 dependent on shear rate

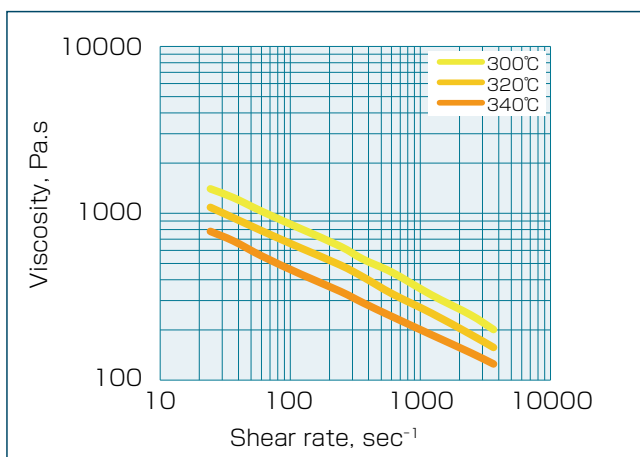

Fig.6.12 Melt viscosity of FZ-3600 dependent on shear rate

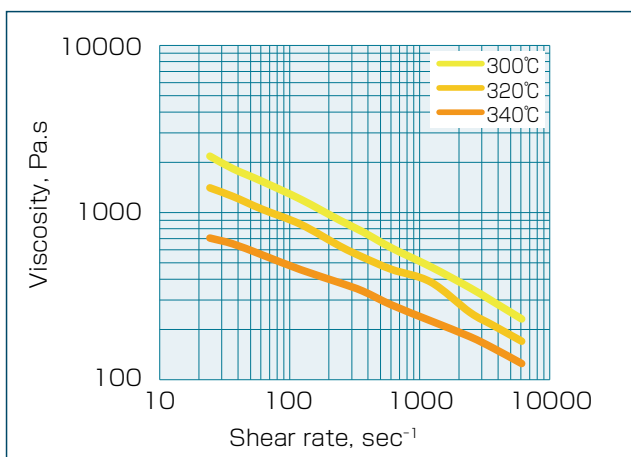

Fig.6.13 Melt viscosity of FZ-6600 dependent on shear rate

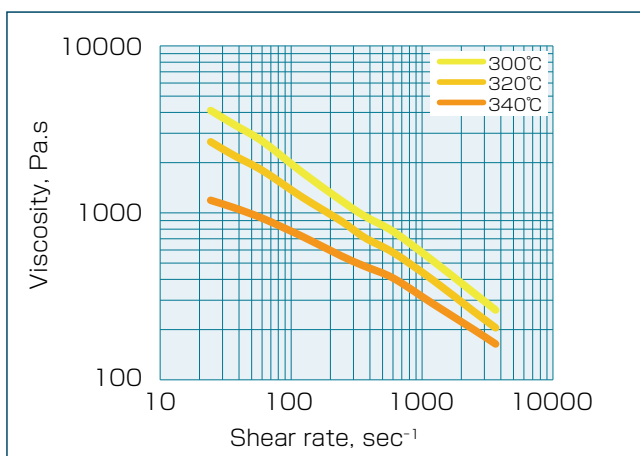

Fig.6.14 Melt viscosity of Z-230 dependent on shear rate

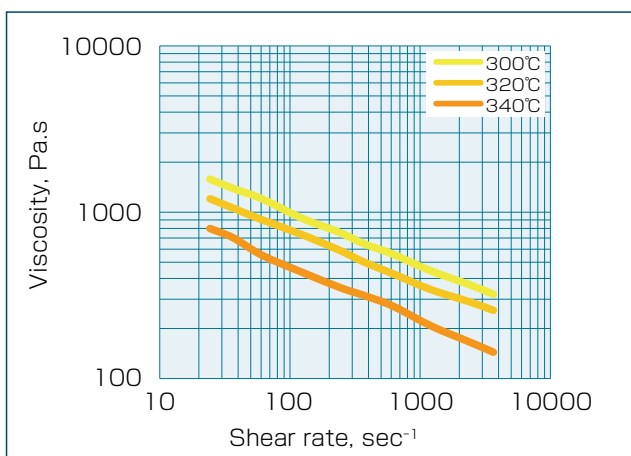

Fig.6.15 Melt viscosity of Z-650 dependent on shear rate

6.7. Molding Conditions and Mechanical Properties

The characteristics of DIC.PPS vary depending on the molding conditions. There are various factors that affect the properties, such as mold temperature, injection pressure, and resin temperature. The mold temperature has the greatest effect since crystallinity of PPS plays an important role in maximizing the properties. The user must take note that almost all properties described in this document are based on specimens that crystallized sufficiently. The following explains the effect of injection pressure, resin temperature and especially mold temperature on DIC.PPS characteristics.

6.7.1. Mold Temperature

Figure 6.16 shows the mold temperature dependence of the deflection temperature under load as a guideline for heat resistance. As the mold temperature decreases, the heat distortion temperature tends to decrease. The reason for this is thought to be the low crystallinity, and such tendency becomes more pronounced as the thickness of the molded product decreases. The recommended standard mold temperature is from 130°C to 150°C.

Figure 6.17 and 6.18 show the relationship between mold temperature, flexural strength and impact strength. Regarding the flexural strength, the mold temperature dependency tends to be small. In terms of impact strength, the impact resistance decreases as the mold temperature increases for both the branched and linear

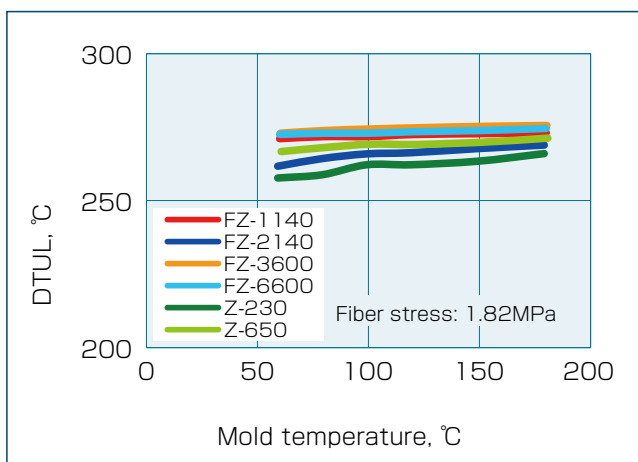

Fig.6.16 Distortion temperature under load of FZ-1140 dependent on mold temperature

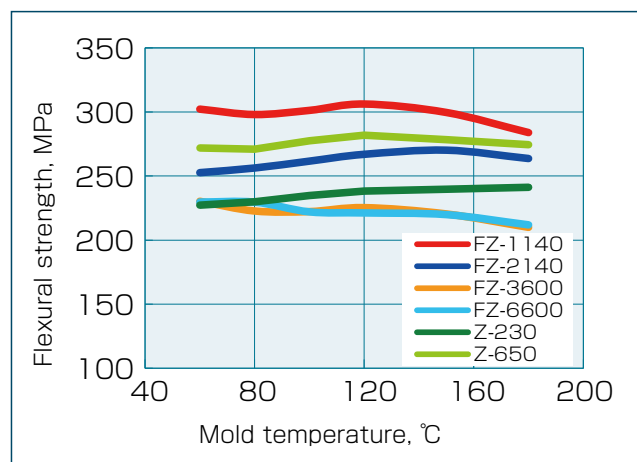

Fig.6.17 Flexural strength dependent on mold temperature

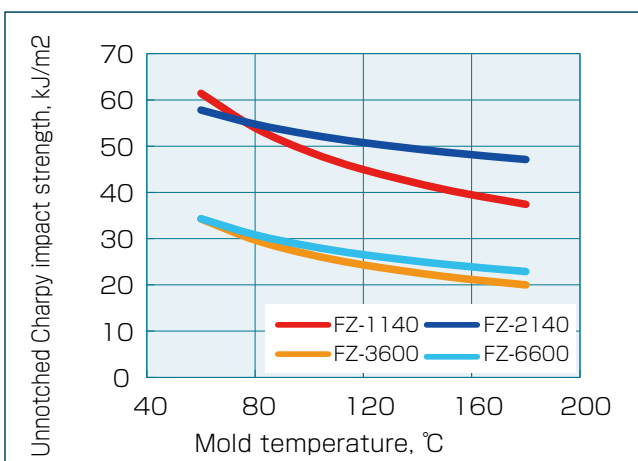

Fig.6.18 Impact strength dependent on mold temperature

type PPS. In other words, the higher the degree of crystallization, the harder and more brittle the material becomes. This is a property common to crystalline resins.

In addition to the mechanical characteristics stated above, the mold temperature is closely related to all the characteristics that correlate with the crys-

tallinity of PPS, such as the surface condition of the molded product, surface hardness, heat-resistant dimensional stability, and mold shrinkage. Figures 6.19 and 6.20 shows the effect of mold temperature on mold surface roughness and hardness. Please refer to “6.5 Mold Shrinkage” for the mold temperature dependence of shrinkage.

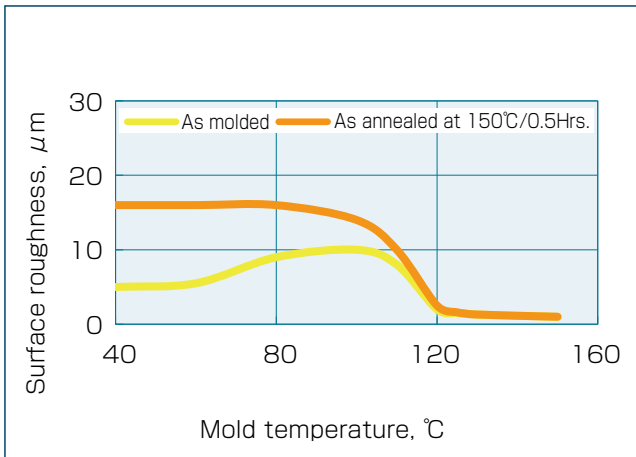

Fig.6.19 Surface roughness depending on mold temperature

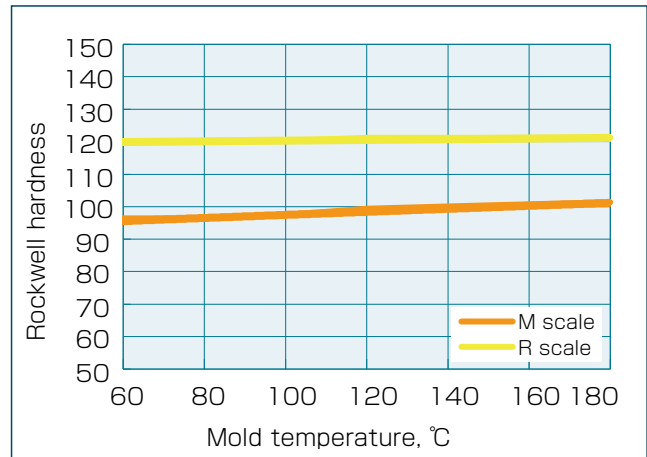

Fig.6.20 Rockwell hardness dependent on mold temperature

6.7.2. Molten Resin Temperature

Even if the resin temperature is controlled within the proper temperature range, the physical properties will change if the resin temperature varies due to the change in cylinder temperature setting. These physical property changes are due to changes in melt viscosity, crystallization speed, and GF orientation. Mechanical properties such as tensile strength, flexural strength, impact strength and weld strength tend to increase as the resin temperature increases. As an example, Fig.6.21

shows the cylinder temperature dependence on tensile strength.

6.7.3. Molding Pressures

The holding pressure is usually in the range of 50-100MPa. However, under certain circumstances, higher pressure may be required. For example, when it is necessary to ensure strict dimensional accuracy of the molded product as shown in Figure 6.22. In general, the higher holding pressure, the higher mechanical properties.

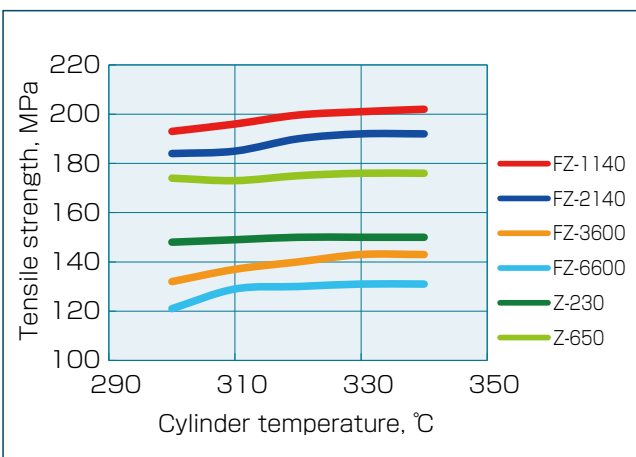

Fig.6.21 Tensile strength of FZ-1140 affected by cylinder temperature

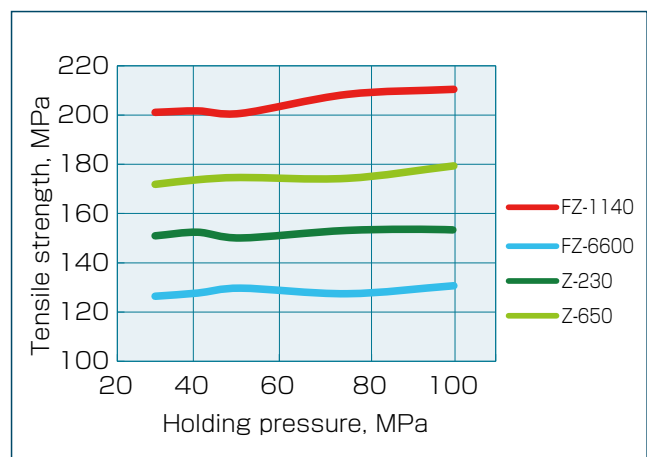

Fig.6.22 Tensile strength affected by holding pressure

7. SECONDARY OPERATION

Secondary operation can be performed for value-adding. Secondary operation processes include machining, adhesive bonding, thermal fusion and ultrasonic fusion, coating, plating and annealing.

7.1 Machining

Machining includes turning, drilling, milling and cutting etc. These processes are possible provided that the tools are made of cemented carbide chip with high hardness and wear resistance. Durable tools are recommended because most PPS grades are filled with inorganic materials like GF. The surface can also be buffed or lapped. Moreover, it is necessary to avoid stress concentration at the corner and fillet, not only during machining but also in the design of molded parts.

Figure 7.1 shows the relationship between stress concentration factor and fillet radii.

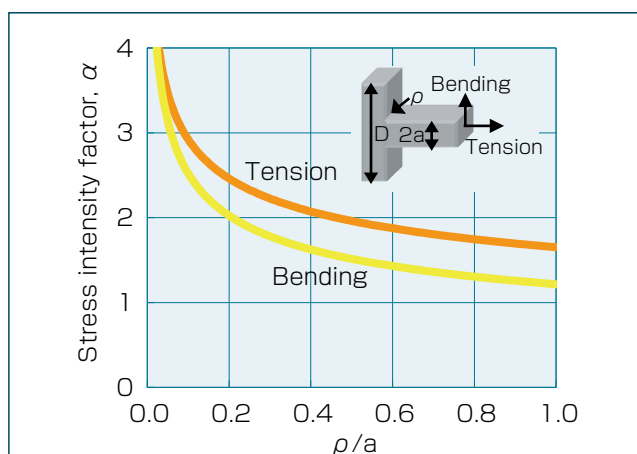

Fig.7.1 Stress intensity factor dependent on ρ/a

7.2. Adhesive Bonding

PPS is extremely chemical resistant and difficult to be joined together with solvent-based adhesives. However, epoxy-based, silicone-based, and cyanoacrylate-based adhesives are usable. In general, linear type FZ-6600 and FZ-2140 show higher adhesive strength than branched type grades. To increase the adhesion strength, the surface of the molded product can be subjected to short wavelength UV treatment, corona treatment, plasma treatment, etc. to increase the surface activity. However, it should be noted that the effectiveness of such surface treatments decreases with time. As a guide, it is recommended to complete the bonding process within 4-5 days after treatments. For silicon bonding, bonding strength is improved when the molded product is annealed several hours at 200°C or higher before the bonding process.

Table 7.1 shows the tensile shear strength data of epoxy adhesive and silicone adhesive.

Table 7.1 Adhesive bonding by tensile-shear strength. (MPa)

Adhesives	Curing	FZ-2140	FZ-6600	Z-230	Z-650
Epoxy					
XNR5002	100°C /60min.	4.8	7.6	11.3	3.7
/XNH5002 ¹⁾	→150°C /180min.				
Silicone					
SE1714 ²⁾	150°C /60min.	5.3	4.9	4.5	2.8

1) Nagase ChemteX Corporation, Two-pack type thermosetting adhesive
Bonding area : 12.5×5mm

2) Dow Corning Toray Co.,Ltd., One-pack type thermosetting adhesive
Bonding area : 12.5×12.5mm

7.3. Welding

Ultrasonic welding, friction welding, heat welding, induction heating welding, etc. are examples of heat induced joining methods. The simplest and most efficient method is ultrasonic welding in which the shear joint design is usually adopted. Figure 7.2 shows the cross-sectional shape dimensions of the joint for reference. Examples of welding conditions are, ultrasonic amplitude of 20-50µm, welding time of 0.2-0.4 seconds and low pressure. Since PPS has high rigidity, density, and strain (elongation) is small, attenuation and propagation of stress waves due to ultrasonic vibrations is difficult and may result in cracks when the welding conditions are severe. In general, the welding conditions become narrower for grades in the order of, grades with less reinforcing fillers > linear type PPS which have large strain (FZ-2140) > FZ-1140 and FZ-6600. Table 7.2 shows the tensile strength per unit length after welding with the specimen shown in Figure 7.3.

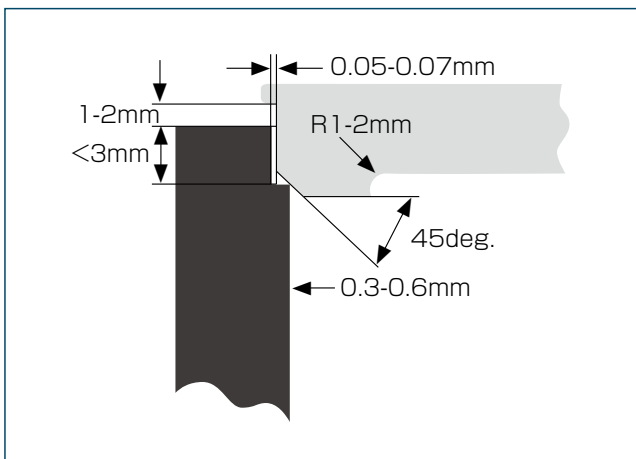

Fig.7.2 Typical design of shear joint by the ultrasonic welding

7.4. Metallization

Aluminum vacuum metallization is possible. When vacuum deposition is performed after primer coating, the deposition surface becomes smooth, but this process can be omitted. In this case, the surface of the molded product is plasma treated in an inert gas atmosphere such as argon to ensure good adhesion with the deposited film.

7.5. Coating

Similar to adhesion, the adhesion of the coating is improved by surface treatment of the molded product. The most suitable paints for DIC.PPS are acrylic urethane-based, followed by acrylic melamine-, epoxy-, and silicone-based coatings. Electrostatic coating is possible with the conductive grades described in 'DIC.PPS grades and characteristics'.

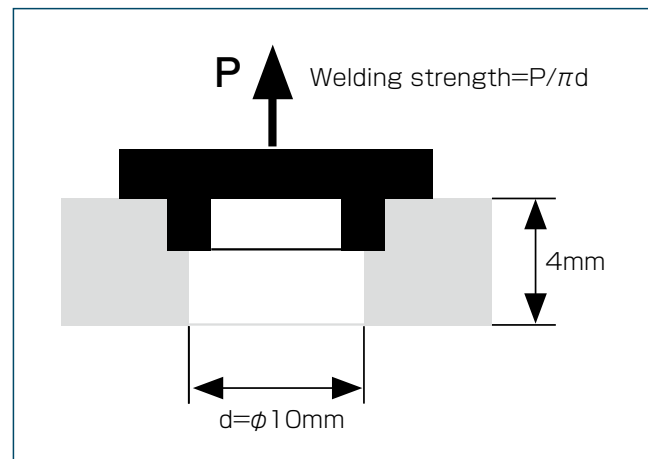

Fig.7.3 Test method of ultrasonic welding

Table 7.2 Ultrasonic welding strength

Amplitude	Pressure	Time	Welding strength	
			FZ-1140	FZ-3600
40 µm	0.28 MPa	0.4 sec	28N/mm	15N/mm
40	0.28	0.2	21	12
40	0.14	0.4	31	14
20	0.28	0.2	22	13
50	0.28	0.3	30	21

7.6. Mechanical Fastening (Self-tapping Screw)

Fastening with screws and bolts is often used to join PPS molded parts or parts made of other materials. For stronger joining strength, the use of molded-in metal screw inserts or ultrasonically staked inserts is recommended. As one of the more convenient joining methods, self-tapping screws is widely used, but the boss inner diameter (hole diameter) and boss wall thickness are important. Figures 7.4 and 7.5 show the data for two types of threaded screws as described in JIS B1115.

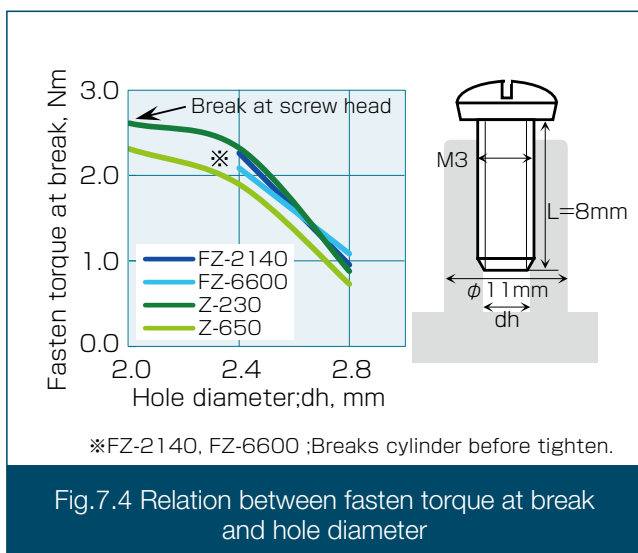

7.7. Annealing Treatment

PPS can reach sufficient crystallinity by using a high temperature mold of 130-150°C during molding. If molding is performed at mold temperatures lower than the recommended temperature range, the crystallinity can be increased by annealing for 1-2 hours at 150°C (Figure 7.6). However, it is necessary to pay attention to dimensional changes when annealing is performed (Figure 7.7).

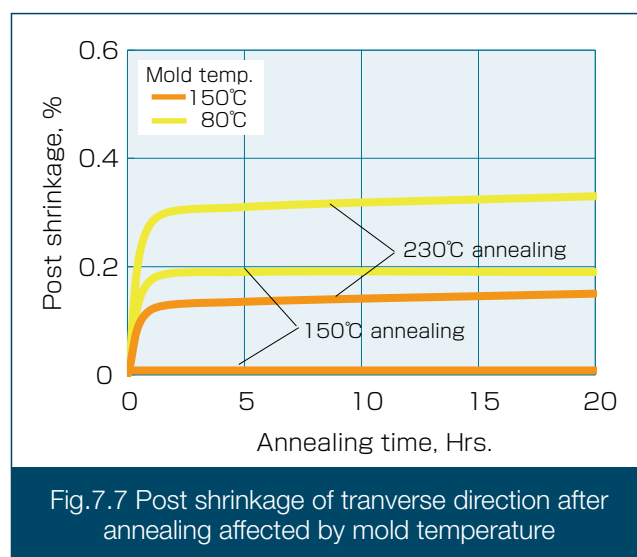
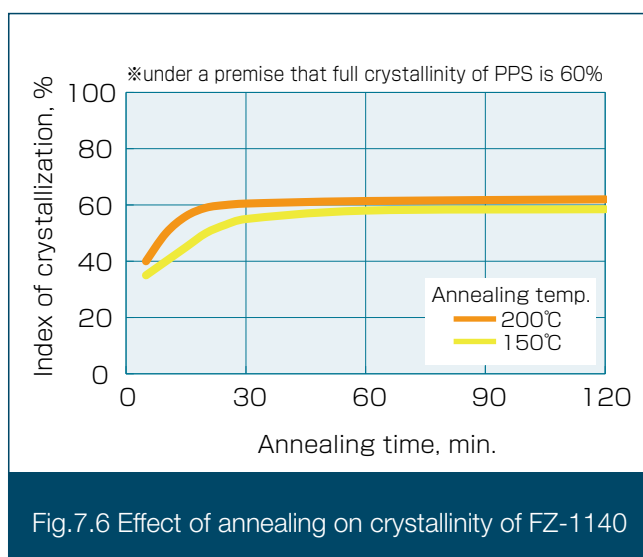
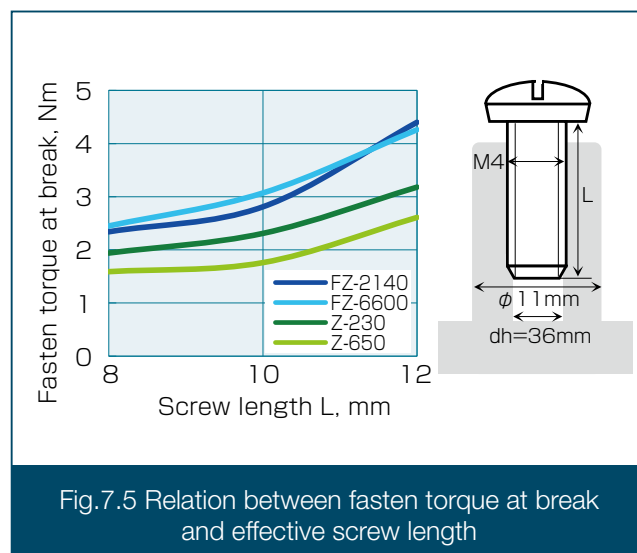

Precautions for Molding

Be aware of the information provided below. To the best of our knowledge, the information contained herein is accurate. However, the manufacturer does not assume any liability whatsoever for the accuracy or completeness of the information contained herein. For more detailed information on safety please refer to the relevant SDS (Safety Data Sheet)

1. Pre-drying of Pellets

Pre-drying at excessively high temperatures or duration longer than necessary may cause discoloration or change in flowability.

2. Suitable Cylinder Temperature

Temperature ranging from 300 to 340°C is considered as appropriate. Heating over 350°C is not advisable and should be avoided. However, considering the wide range of DIC.PPS, the appropriate cylinder temperature for each DIC.PPS grades should be confirmed. For safety reasons, the temperature range of the grades which contain PTFE* should be set around 290-320°C and heating over 330°C should be avoided.

*: PTFE; Poly Tetra Fluoro Ethylene

3. Residence Time in Cylinder

The following is a guide to the residence time of resins in cylinder. It may vary depending on the grades of DIC.PPS, conditions and injection molding machines.

300°C: less than 60 min.

320°C: less than 30 min.

4. In case of molding trouble

In case of resin decomposition or similar situations, lower the cylinder temperature and purge the remaining resin out.

5. Shutdown

Purge the cylinders with high viscosity resin materials, leave the screw forward then switch off the heaters.

6. Restrictions on additional ingredients

Do not mix colorants, additives or other resins with DIC.PPS except for those recommended by DIC.

7. For safety during operation

7-1.

Ventilation system is recommended and is compulsory for PTFE containing grades.

7-2.

Wear protective goggles and gloves.

7-3.

Keep operator away from the nozzle section.

7-4.

Do not touch molten resin without gloves.

8. Disposal

Dispose or incinerate under safe conditions in accordance with local regulations.

Japan	DIC Corporation Tokyo, Japan Tel: +81-3-6733-5943
Europe	Sun Chemical Group GmbH Cologne, Germany Tel: +49-221-96751-100
North America	Sun Chemical Corporation Parsippany, NJ USA Tel: +1-973-404-6600
Asia - Pacific	DIC Asia Pacific Pte Ltd Singapore Tel: +65-6224-0600 DIC Graphics (Thailand) Co., Ltd. Bangkok, Thailand Tel: +66-2-260-6630-7 DIC (Malaysia) Sdn. Bhd. Malaysia Tel: +60-3-5191-0033 DIC South Asia Private Ltd Mumbai, India Tel: +91-22-4938-8003
China	DIC (Shanghai) Co., Ltd. Shanghai, People's Republic of China Tel: +86-21-6228-9911 DIC (Guangzhou) Co., Ltd. Guangzhou, People's Republic of China Tel: +86-20-8384-9737
Hong Kong	DIC Trading (HK) Ltd. Hong Kong Tel: +852-2723-6111
Taiwan	DIC (Taiwan) Ltd. Taipei, Taiwan Tel: +886-2-2551-8621
Korea	DIC Korea Corp. Seoul, Republic of Korea Tel: +82-2-317-6200

<http://www.dic-global.com/>

DIC Corporation

Tokyo

DIC Building, 7-20, Nihonbashi 3-chome, Chuo-ku, Tokyo 103-8233, Japan TEL: +81-3-6733-5943

Osaka

5-19, Kyutaro-machi 3-chome, Chuo-ku, Osaka 541-8525, Japan TEL: +81-6-6252-9533

Nagoya

7-15, Nishiki 3-chome, Naka-ku, Nagoya 460-0003, Japan TEL: +81-52-951-0703